

# Wireless World

RADIO, TELEVISION AND ELECTRONICS

## VOLUME LVII

JANUARY - DECEMBER 1951

*ALL RIGHTS RESERVED*

Published from the Offices of "WIRELESS WORLD"  
ILIFFE & SONS LTD., DORSET HOUSE, STAMFORD ST., LONDON, S.E.1.

## GENERAL INDEX

To facilitate reference the month of issue as well as the page number is given.

The General Index is followed by a Classified Index under the headings of Aerials, Circuitry, Design, Electronics, Manufacturers' Products, Miscellaneous, Modulation, Organization, Propagation, Radiolocation, Sound Reproduction, Television, Test and Measurement, Transmission, Valves and Thermionics, Books, Illustrations and Authors. References to Authors, Books and Illustrations appear only in the Classified Index.

- A.F.** Bridge Amplifier; Sensitive Null Detector, by M. G. Scroggie, 175, May
- A.G.C.** Amplifier, by S. W. Amos and G. G. Johnstone, 415, Oct.; 452, Nov.
- A.M./F.M.** Experiments, Wrotham, 141, Apr.
- A.M. versus F.M.** (*Correspondence*), 39, Jan.; 122, Mar.; 146, Apr.; 220, June; 263, July; 407, Oct.; 458, Nov.; (*Editorials*), 167, May; 209, June; (*News*), 372, Sept.; Brit. I.R.E. Paper, 350, Sept.
- Accumulator**, Exide Unspillable LPM4, 119, Mar.
- Acoustics of the Royal Festival Hall**, 244, June
- **Studio**, B.B.C. Measurement, 435, Oct.
- Acustica**, New International Journal (*News*), 16, Jan.
- Aerial**, Eddystone Amateur Beam, 475, Nov.
- **Helical**, 262, July
- **Merryweather O.B. Mobile**, 75, Feb.
- **Multicoupler**, Plessey, 36, Jan.
- **System**, Wrotham, by C. Gillam, 210, June; 279, July
- **T-Match** Television, by B. Mayson, 404, Oct.
- **Temporary Vision**, by F. D. Bolt, 13, Jan.
- Air Communications**, Multi-Carrier, 92, Mar.
- **Navigational Aids**, by Basil Clarke, 329, Aug.
- **Traffic Control Records** (*Correspondence*), 123, Mar.
- Aircraft Radio on Show**, S.B.A.C., 418, Nov.
- Airfield Surface Movement Indicator**, 170, May
- Airmet** (*News*), 102, Mar.
- Aluminium Joining**, 181, May; (*Correspondence*), 408, Oct.; 500, Dec.
- Aluminizing Cathode-Ray Tubes**, by S. R. Neuberger and J. H. Jupe, 245, June
- Amateur F.M. Frequencies** (*News*), 461, Nov.
- **Radio Developments**, by J. P. Hawker, 463, Nov.
- **Television**, 319, Aug.
- **Convention** (*News*), 225, June
- **Frequencies** (*News*), 313, Aug.; 461, Nov.
- **Dutch**, (*News*), 102, Mar.
- American Coast-to-Coast Television** (*News*), 461, Nov.
- **Insularity** (*Correspondence*), 179, May
- **Walkie-Talkie**, R.C.A., 291, July
- **"Wartime" Amateur Frequencies** (*News*), 139, Apr.
- Amplified Automatic Gain Control**, by S. W. Amos and G. G. Johnstone, 415, Oct.; T.R.F. Receiver, 452, Nov.
- Amplifiers for Disc Recording**, B.S.R.A. Lecture, 14, Jan.
- **Stabilizing Feedback**, by Thomas Roddam, 112, Mar.
- Approach to "High Fidelity."** 289, July
- Asian Conference on Broadcasting** (*News*), 224, June
- Association of Professional Recording Studios**, 12, Jan.
- **Public Address Engineers' Exhibition**, 259, 265, July; (*News*), 182, May
- Astronomy**, Radio, 275, July
- Athlone Fellowships** (*News*), 462, Nov.
- Attenuation of Screened Rooms**, E.R.A. Report, 151, Apr.
- Audio Convention**, Brit. I.R.E., 409, Oct.
- **Frequency Valve Voltmeter**, by S. Kelly, 215, June
- Australian Time Signals** (*News*), 138, Apr.
- Automatic Course Plotting**, 143, Apr.; (*News*), 501, Dec.
- **Monitoring** (*Correspondence*), 322, Aug.; 457, Nov.
- B.B.C.** (G.P.O. Standards (*Correspondence*), 263, July; 369, Sept.
- **Beveridge Committee's Report**, 81, Feb.; (*Editorial*) 125, Apr.
- **Broadcasting Inquiry** (*News*), 15, Jan.
- **Daventry**, New Transmitter (*News*), 137, Apr.; article by R. W. Hallows, 236, June
- **Exhibition** (*News*), 269, July
- **Holme Moss Opens**, 473, Nov.
- **Holme Moss Tests** (*News*), 313, Aug.; 412, Oct.
- B.B.C. Metre-wave Broadcasting** *Sub Judice* (*Editorial*), 209, June; (*Correspondence*), 263, July
- **New Appointments** (*News*), 17, Jan.
- **New Governors** (*News*), 15, Jan.
- **P.M.G.'s Statement on V.H.F.** (*Editorial*), 337, Sept.
- **Questions about E.H.F. Broadcasting** (*Editorial*), 167, Apr.
- **Report**, 1950/1 (*News*), 461, Nov.
- **Standard Frequency Transmissions** 378, Sept.
- **Standardized Chassis**, 261, July
- **Stations**, List, 104, Mar.
- **Studio Acoustics**, 435, Oct.
- **Television Map**, 82, Feb.
- **Television Progress** (*News*), 15, Jan.
- **Twelve New Low-Power Stations** (*News*), 268, July; 412, Oct.; 463, Nov.
- **Wenloe Television Station** (*News*), 102, Mar.
- **Wrotham Transmitter**, 141, Apr.
- **Year Book**, 1952 (*News*), 502, Dec.
- **Zoom Lens**, 312, Aug.
- B.S.I. Committee's Report** (*News*), 138, Apr.
- **Jubilee Exhibition** (*News*), 182, May.
- B.S.R.A.** Amplifiers for Disc Recording, 14, Jan.
- **Annual Convention**, 260, July
- **Electromagnetic Gramophone Pickups**, Lecture, 238, June
- **Exhibition** (*News*), 182, May; Review, 265, July
- **Frequency Test Records**, Discussion, 231, June
- **Officers** (*News*), 374, Sept.
- **Piezoelectric Pickups**, Lecture, 18, Jan.
- B.V.A. Officers** (*News*), 413, Oct.
- Bad Radio Teaching** (*Correspondence*), 500, Dec.
- Baird Plaque** (*News*), 461, Nov.
- Ball Race**, Miniature Bearings, 296, July
- Band-pass Converters**, by H. B. Dent, 67, Feb.
- Bass without Big Baffles**, by K. A. Exley, 132, Apr.; (*Correspondence*), 219, May; 264, July; 321, Aug.; 360, Sept.; 408, Oct.
- Batteries**, Re-activating Dry, by R. W. Hallows, 434, Oct.; (*Correspondence*), 457, Nov.
- BEVERIDGE REPORT:**
- **Broadcasting Monopoly** (*Editorial*), 125, Apr.
- **Cinema Television** (*News*), 137, Apr.
- **Government White Paper on Report** (*Editorials*), 301, Aug.; 337, Sept.
- **Meetings of Broadcasting Committee** (*News*), 15, Jan.
- **Metre-wave Broadcasting** (*Editorials*), 167, May; 209, June; 439, Nov.; (*Correspondence*), 263, July; 500, Dec.
- **Mystery Broadcasting** (*Editorial*), 337, Sept.; article by Thomas Roddam, 341, Sept.; (*Correspondence*), 499, Dec.
- **Recommendations of the Broadcasting Committee**, 81, Feb.; (*Correspondence*), 121, Mar.
- Binary and Decimal Systems: Tens or Twos?**, by "Cathode Ray," 351, Sept.
- Binaural Broadcasting**, 371, Sept.
- Brit. I.R.E. Annual General Meeting**, 461, Nov.
- **Eliphop Projection Television**, paper, 424, Oct.
- **Election of Officers**, 461, Nov.
- **Graduateship Examination**, 139, Apr.
- **Hearing Aid Problems**, paper, 107, Mar.
- **Premiums**, 413, Oct.
- **Progress in Loudspeaker Design**, paper, 18, Jan.
- **V.H.F. Broadcasting**, paper, 350, Sept.
- **1951 Convention**, 101, Mar.; 138, Apr.; 224, June; 268, July; 314, Aug.; 350, 372, Sept.; 409, Oct.
- Broadcast Receiver Design**, I.E.E. discussion, 72, Feb.
- Broadcasting Committee's Inquiry** (*News*), 15, Jan.; Summary of Recommendations, 81, Feb.; (*Correspondence*), 121, Mar.; 263, July; 499, 500, Dec.; (*Editorials*), 125, Apr.; 167, May; 209, June; 301, Aug.; 337, Sept.; 439, Nov.
- **of Records** (*Correspondence*), 219, June
- Business Radio**, P.M.G.'s Statement (*News*), 372, Sept.; 412, Oct.
- **Details of Service**, 498, Dec.
- CABLE**, Telcon Transmitter Feeder, 37, Jan.
- Capacitors**, Electrolytic, by G. W. A. Dummer, 510, Dec.
- **in See-Saw Circuit** (*Correspondence*), 180, May
- Cathode Follower Circuit** (*Correspondence*), 180, May; 220, June
- Cathode-Ray Tubes**, Aluminizing, by S. R. Neuberger and J. H. Jupe, 245, June
- **English Electric Steel** (*News*), 16, Jan.
- **for Television**, G.E.C., 297, July
- Chokes**, R.F., by "Cathode Ray," 494, Dec.
- Church House**, Westminster, Sound Reinforcing Installation, by D. W. Pipe, 117, Mar.
- Cinema Television** (*Editorial*), 83, Mar. (*News*), 137, Apr.
- Circuit Diagrams, Aid to Reading: Grouped Component References**, by L. Bainbridge-Bell, 115, Mar.; (*Correspondence*), 219, June
- Coil Turrets**, Denco Miniature, 519, Dec.
- Comité International de Télévision**, New Journal (*News*), 502, Dec.
- Component Specifications**, R.I.C., 238, June; 294, July; 484, Dec.
- Computer**, New Digital, 333, Aug.
- **"Nimrod"**, 292, July
- Computers**, by "Cathode Ray," 419, Oct.; (*Correspondence*), 458, Nov.; 499, Dec.
- Consol Charts** (*News*), 139, Apr.; 270, July
- Constant-Current Generator**, The Valve as, by "Cathode Ray," 152, Apr.
- Continental Gramophone Records**, 484, Dec.
- Continuously Variable Mains Transformer**, by H. E. Styles, 306, Aug.
- Converters**, Band-pass, by H. B. Dent, 67, Feb.
- Copenhagen Intermediate Frequencies** (*News*), 15, Jan.; 360, Sept.
- Countering Mains Fluctuations**, by Graham Woodville, 148, Apr.
- Crystal Oven**, Pye Miniature, 163, Apr.
- **Set, A Modern**, by B. R. Bettridge, 338, Sept.; (*Correspondence*), 408, Oct.; 457, Nov.; 500, Dec.
- Curious Effect** (*Correspondence*), 40, Jan.
- Cylindrical Chassis**, Murphy, 324, Aug.
- D.C. Amplifiers**, Reducing Drift in, (*Correspondence*), 80, Feb.
- D.S.I.R. Telecommunications Research**, 431, Oct.
- Danish Television** (*News*), 463, Nov.
- Daventry Station**, New, by R. W. Hallows, 236, June
- Decca Chain**, French, (*News*), 462, Nov.
- **Flight Log Computer**, 143, Apr.; (*News*), 501, Dec.
- **Navigator**: N. British Chain opens (*News*), 269, July; 313, Aug.
- Design for Servicing**, by M. G. Scroggie, 396, Oct.
- Diathermy Interference** (*Correspondence*), 370, Sept.; 457, Nov.; 500, Dec.
- Dictation Machine**, Magnetic, 196, May
- Digital Computer**, New, 333, Aug.
- Dimensions**, by "Cathode Ray," 469, Nov.
- Diode Detector Distortion**, by W. T. Cocking, 171, May
- Diodes for Drift Correction** (*Correspondence*), 80, Feb.
- Distribution of Sound** (*Editorial*), 43, Feb.
- Domestic Radio on Show** (*Editorial*), 383, Oct.
- Dutch Television Stations and Frequencies** (*News*), 101, Mar.; 462, Nov.



- E.H.F. Broadcasting (Correspondence)**, 39, Jan.; 122, Mar.; 146, Apr.; 220, June; 263, July; 407, Oct.; 458, Nov.; (Editorials), 167, May; 209, June; 439, Nov.; (News), 372, Sept.; Brit. I.R.E. Paper, 350, Sept.
- **Communications (Correspondence)**, 122, Mar.
- E.H.T. Booster, Flyback**, by A. H. B. Walker, 27, Jan.
- **from an R.F. Oscillator**, by C. J. Dickinson, 70, Feb.
- **Systems, Ringing-Choke**, by W. T. Cocking, 444, Nov.; 513, Dec.
- E.M.F. or P.D.?** (Correspondence), 79, Feb.
- E.M.I. Electronic Scholarships (News)**, 314, Aug.
- Earls Court Exhibition, 1951 (News)**, 137, Apr.; (Editorials), 337, Sept.; 383, Oct.; Guide, 361, Sept.; Review, 384, Oct.; Attendance (News), 412, Oct.; (Correspondence), 499, Dec.
- Earphone, Bonochoird Miniature**, 475, Nov.
- EDITORIALS**
- **Distribution of Sound**, 43, Feb.
- **Domestic Radio on Show**, 383, Oct.
- **Encouraging Technical Writers**, 479, Dec.
- **Festival Television**, 301, Aug.
- **Fire and Shock**, 1, Jan.
- **Government Views on the B.B.C.**, 301, Aug.
- **Home Broadcast Recording**, 125, Apr.
- **Illegal Interference**, 337, Sept.
- **Metre-wave Broadcasting Sub Judge**, 209, June; (Correspondence), 263, July
- **Middle-age Musings**, 125, Apr.
- **National Radio Exhibition**, 337, Sept.
- **New Broadcasting System?**, 337, Sept.
- **Questions about E.H.F. Broadcasting**, 167, May; (Correspondence), 263, July
- **Sound Reproduction**, 251, July
- **Television in the Cinema**, 83, Mar.
- **Uses of Metre-wave Broadcasting**, 439, Nov.; (Correspondence), 500, Dec.
- Educational Filmstrips**, Mullard, 375, Sept.
- Efficiency Line-Scan Circuits**, by W. T. Cocking, 302, Aug.; 347, Sept.; 425, Oct.
- Eidophor Projection Television System**, Brit. I.R.E. Convention Paper, 424, Oct.
- Electrical Dangers (Correspondence)**, 80, Feb.; 180, May
- Electricity Power Cuts Warning (News)**, 462, Nov.; 502, Dec.
- Electro Physiological Technologists Association Annual Meeting (News)**, 183, May
- Electrolytic Capacitors**, by G. W. A. Dummer, 510, Dec.
- Electromagnetic Gramophone Pickups**, B.S.R.A. paper, 238, June
- Electronic Flight Simulator**, 130, Apr.
- **Fluxmeter**, by P. L. Taylor, 161, Apr.
- **Photography**, Mullard, 87, Mar.
- Eltra II, Marconi**, 232, June
- Engineering Conference, Joint, (News)**, 224, June
- Europe's V.H.F. Stations (News)**, 137, Apr.
- EXHIBITIONS**
- **Anglo-French**, 138, Apr.
- **Association of Public Address Engineers**, 182, May; 259, 265, July.
- **B.B.C.**, 269, July.
- **B.I.F. 1952**, 374, Sept.
- **B.S.R.A.**, 182, May; 265, July.
- **British Standards Golden Jubilee**, 182, May.
- **Electronics**, 268, July.
- **Indian**, 184, May.
- **Instruments**, 268, July.
- **Manchester 1952**, 412, Oct.
- **Model Engineer**, 269, July.
- **Telearchies**, 433, Oct.
- **National Radio and Television Show**, 1951, 137, Apr.; (Editorials), 337, Sept.; 383, Oct.; Guide, 361, Oct.; Review, 384, Oct.
- **National Radio Show, 1952**, 412, Oct.
- **Paris Television**, by A. V. J. Martin, 459, Nov.
- **Physical Society**, 189, May.
- **Plastics**, 269, July.
- **R.E.C.M.F.**, 102, Mar.; 134, Apr.; 185, 191, May.
- **R.E.C.M.F.**, 193, 462, Nov.
- **R.S.G.B.**, 163, May; 413, Oct.; 461, Nov.; 503, Dec.
- **S.B.A.C.**, 448, Nov.
- **South Bank**, 173, May.
- **Television Society**, 501, Dec.
- F.M./A.M. Experiments**, Wrotham, 141, Apr.
- F.M. American Views (Correspondence)**, 79, Feb.
- **and Exports (Correspondence)**, 322, Aug.
- **in Germany (News)**, 463, Nov.
- **Italian Network (News)**, 15, Jan.
- **Receiver, Design for**, by J. G. Spencer, 440, Nov.; 487, Dec.
- F.M. versus A.M. (Correspondence)**, 39, Jan.; 122, Mar.; 146, Apr.; 220, June; 263, July; 407, Oct.; 458, Nov.; (Editorials), 167, May; 209, June; (News), 372, Sept.; Brit. I.R.E. paper, 350, Sept.
- FMQ**, by W. S. Mortley, 399, Oct.
- Faraday Medallist**, T. E. Ekersley, (News), 101, Mar.
- Feedback Amplifiers, Stabilizing**, by Thomas Roddam, 112, Mar.
- Feeder Unit, Radio**, by J. F. O. Vaughan, 480, Dec.
- Festival of Britain: Radio Equipment at the South Bank**, 173, May; Festival Hall Acoustics, 244, June; Television at the South Bank, 244, June; Stereophonic Sound in Telekinema, 223, June, Telekinema Demonstrations (Correspondence), 264, July; (Editorial), 301, Aug.; Amateur Participation, 101, Mar.; 139, Apr.; 270, July
- Filter, Unusual Ladder**, by F. G. G. Davey, 31, Jan.
- Fire and Shock (Editorial)**, 1, Jan.; article by F. C. Connelly, 2, Jan.; (Correspondence), 145, Apr.; Fire Protection Assn. Report, 69, Feb.
- Flight Simulator, B.O.A.C.**, 130, Apr.
- Fluxmeter, Electronic**, by P. L. Taylor, 161, Apr.
- Flyback E.H.T. Booster**, by A. H. B. Walker, 27, Jan.
- French Decca Chain (News)**, 462, Nov.
- **Television (News)**, 225, June
- Frequency-Modulated Quartz**, by W. S. Mortley, 399, Oct.
- **Modulation, by "Cathode Ray,"** 193, May; 239, June; 271, July; (Corrections), 328, Aug.
- **Test Records, B.S.R.A. Discussion**, 231, June
- Fuses, Temperature**, 294, July
- G.P.O./B.B.C. Standards (Correspondence)**, 263, July; 369, Sept.
- **Rugby Station Jubilee (News)**, 102, Mar.
- G.R.S.E. Classes of Membership (News)**, 16, Jan.
- **War Office Agreement (News)**, 139, Apr.
- Gas Discharge Tubes**, 293, July
- Generator, Square-Wave**, by O. C. Wells, 35, Jan.; (Correction), 103, Mar.; (Correspondence), 322, Aug.
- German Television (News)**, 412, Oct.
- Germanium Crystal Set**, by B. R. Bettridge, 338, Sept.; (Correspondence), 408, Oct.; 457, Nov.; 500, Dec.
- **Diodes**, by R. T. Lovelock and J. H. June, 57, Feb.
- **Rectifier, G.E.C.**, 37, Jan.
- **Government Views on the B.B.C. (Editorials)**, 301, Aug.; 337, Sept.
- Gramophone Turntable Speeds**, by G. F. Dutton, 227, June
- Grouped Component References**, by L. Bainbridge-Bell, 115, Mar.; (Correspondence), 219, June
- HARBOUR Control Radar**, 105, Mar.; (Correspondence), 220, June
- Hearing Aid, Amplivox Miniature**, 296, July
- **Bonochoird Miniature**, 37, Jan.
- **Problems**, Brit. I.R.E. paper, 107, Mar.
- Helical Aerial**, General Electric of America, 262, July
- High-Definition Films Ltd. Company formed (News)**, 502, Dec.
- **Television**, by R. W. Hallows, 197, May; (Correspondence), 322, Aug.
- **U.S.**, 156, Apr.
- High-Power Klystron**, 354, Sept.
- Holme Moss Modifications for I.F. Television Set**, 286, July
- **Television Station Opens**, 473, Nov.
- **Tests (News)**, 313, Aug.
- Honours, Birthday (News)**, 269, July
- Horn Loading**, Brit. I.R.E. paper, 18, Jan.
- House of Lords, Tannoy Installation**, 312, Aug.
- How Reliable is a Radio Valve?** I.E.E. discussion, 91, Mar.
- **Television Works**, G.-B. Instructional Film (News), 183, May
- **to Choose a Valve**, by Thomas Roddam, 221, June; (Correction), 324, Aug.
- I.E.E. Annual Report (News)**, 269, July
- **Awards (News)**, 373, Sept.
- **Broadcast Receiver Design**, discussion, 72, Feb.
- **Council (News)**, 374, Sept.
- I.E.E. Faraday Medallist (News)**, 101, Mar.
- **How Reliable is a Radio Valve?** discussion, 19, Mar.
- **Joint Engineering Conference (News)**, 224, June
- **Nervous System as a Communication Network**, paper, 6, Jan.
- **Radio Section Committee (News)**, 374, Sept.
- **Television Convention (News)**, 138, Apr.; 412, Oct.
- I.F. After Copenhagen**, 360, Sept.
- I.P.R.E. North-Eastern Section formed (News)**, 139, Apr.
- I.S.W.C. Competitions (News)**, 17, Jan.
- Ignition Interference (News)**, 182, May
- **Suppressor**, by Ronald G. Young, 451, Nov.
- Initiation Nickel Plating, Metal Processes Ltd.**, 460, Nov.
- Indoor Television Aerial**, by H. Page, 168, May
- Industry and E.H.F. (Correspondence)**, 263, July
- Institute of Physics Annual Report (News)**, 269, July
- **Graduateship Examination (News)**, 412, Oct.
- Interference, Diathermy (Correspondence)**, 370, Sept.; 457, Nov.; 500, Dec.
- **Illegal (Editorial)**, 337, Sept.
- **Sources of**, 468, Nov.
- Intermodulation Distortion in Gramophone Pickups**, by S. Kelly, 256, July; (Correspondence), 370, Sept.
- **Testing**, by E. W. Berth-Jones, 233, June
- International Conference at Geneva (News)**, 372, Sept.
- Ionosphere Review: 1950**, by T. W. Beunington, 109, Mar.
- Italian F.M. (News)**, 15, Jan.
- JOINTING Aluminium**, 181, May; (Correspondence), 408, Oct.; 500, Dec.
- LEGITIMIZING the "Put" (Correspondence)**, 321, Aug.; 407, Oct.; 458, Nov.; 499, Dec.
- LETTERS TO THE EDITOR**
- **A.M. versus F.M.**, R. C. Burnell, 39, Jan.; F. A. Ruddle, 122, Mar.; W. C. Cruttenberg, 146, Apr.; J. R. Brinkley, 220, June; F. Blackburn, F. H. Beaumont, 407, Oct.; W. M. Dalton, 458, Nov.
- **Air Traffic Control Records**, E. L. Baddeley, 123, Mar.
- **American Insularity**, A. Cribb, Terence R. Bond, 179, May
- **Automatic Monitoring**, R. Danziger, 322, Aug.; F. A. Peachey, 457, Nov.
- **B.B.C./G.P.O. Standards**, C. R. White, 263, July; W. J. Maclean, A. A. Cotterell, J. Brannall, 369, Sept.
- **Bad Radio Teaching**, Mark Owey, 500, Dec.
- **Bass Without Big Baffles**, I. E. A. Bourne, 219, June; K. A. Exley, 264, July, 321, Aug., 369, Sept., 408, Oct.; F. D. C. Baker, 264, July; G. A. Briggs, O. G. Kerslake, 321, Aug.; E. R. Veator, 370, Sept.
- **Beauty and the Beholder**, W. Wilson, 40, Jan.
- **Beginnings of Radar**, J. A. Walker, 122, Mar.
- **Beveridge Report**, Hugh Tilly, "Radiophare," 121, Mar.
- **Broadcasting of Records**, E. Jeffery, 219, June
- **Capacitors in See-Saw Circuit**, J. E. Draper, 180, May
- **Cathode Follower Circuit**, S. H. Finn, 180, May; F. Butler, 220, June
- **Crystal Menace?** C. Kidd, 408, Oct.; B. R. Bettridge, 457, Nov.; F. A. Ruddle, 500, Dec.
- **Curious Effect**, R. Ritter, R. G. Parr, 40, Jan.
- **"Decentralized" Broadcasting**, W. H. Cazaly, 500, Dec.
- **Diathermy Interference**, R. Cussins, 370, Sept.; H. Willan Critchley, 457, Nov.; P. L. Everrett, 500, Dec.
- **Diodes for Drift Correction**, D. A. Bell, 80, Feb.
- **E.H.F. Communications**, H. N. Gant, 122, Mar.
- **E.M.F. or P.D.?** Henry Morgan, 79, Feb.
- **Earls Court Television**, I. G. Benbough, 499, Dec.
- **Electrical Dangers**, Harry Crampin, 80, Feb.; T. J. Wynn, 180, May

Letters to the Editor (contd.)

F. M.: American Views, Edwin H. Armstrong, Charles Anderson, 79, Feb.  
 F.M. and Exports, C. I. Orr-Ewing, 322, Aug.  
 Festival Demonstrations, W. MacLanahan, 264, July  
 Good Example: Interference Suppression, G. W. M. Lush, 80, Feb.  
 Grouped Component References, W. H. O. Banham, 219, June  
 Industry and E.H.F., D. A. Bell, J. R. Brinkley, 263, July  
 Innocent Pentode, Thomas Roddam, 369, Sept.  
 Intermodulation Tests, L. J. Elliott, 370, Sept.  
 Joining Aluminium, P. A. Raine, 408, Oct.; A. E. Crawford, 500, Dec.  
 Legitimizing the "Puff," A. C. Kay, 321, Aug., 499, Dec.; V. Mayes, 407, Oct.; V. J. de Grijp, 458, Nov.  
 Nomenclature, O. S. Puckle, 321, Aug.; L. Bainbridge-Bell, 407, Oct.  
 Over-Centralization, L. MacNaughton, 219, June  
 Phase Shift Oscillators, W. Bacon, D. P. Salmon, 39, Jan.  
 Pickup Design, J. H. Brierley, 81, Feb.; Peter J. Baxandall, Ralph L. West, 146, Apr.  
 — Input Circuit, J. G. Knapp, 40, Jan.  
 Power-Cut Radio, I. G. Benbough, 123, Mar.  
 Pulse Power, S. Cook, 499, Dec.  
 Radio in the Jungle, D. R. Saben, 179, May  
 Reactivating Dry Batteries, A. Edwin Stevens, Thomas G. Ward, 457, Nov.  
 Recording Studios, M. L. Gayford, 458, Nov.  
 Redundant Word?, R. L. Hackworth, 458, Nov.; Henry Morgan, 499, Dec.  
 Resistor Colour Coding, R. Reeves, 80, Feb.  
 Screened Valves, Keith R. Brook, 408, Oct.  
 Square-Wave Generator, R. Williamson, 322, Aug.  
 Stereophonic Sound, M. G. Scroggie, 145, Apr.  
 Television Colour Coding, L. A. C. Hill, 80, Feb.  
 — Fire Hazard, K. S. Phillips, 145, Apr.  
 — Licences, M. J. J. Brons, 220, June  
 — Load, M. G. Scroggie, 39, Jan.  
 — Relay Loss, G. H. Ball, 145, Apr.; G. L. Stephens, 220, June  
 — Visor, "I.S.M.C.," 122, Mar.  
 Thermal Soldering Shunt, Joseph Clegg, 220, June  
 Thorn Needles, C. E. Watts, Stanley Kelly, 121, Mar.; A. M. Pollock, 145, Apr.  
 1,000-Line Will of the Wisp, H. G. M. Spratt, 322, Aug.  
 Tolerances and Errors, "Cathode Ray," 41, Jan.  
 Valve Priorities, Telefunken G.m.b.H., 370, Sept.  
 — Standardization, T. L. Franklin, 500, Dec.  
 — Symbols, E. Jeffery, 179, May  
 What is a Polar Diagram?, L. Bainbridge-Bell, 220, June  
 Licences, 55, Feb.; 102, Mar.; 139, Apr.; 183, May; 225, June; 269, July; 313, Aug.; 374, Sept.; 413, Oct.; 462, Nov.; 503, Dec.  
 Line-Scan Circuits, Efficiency, by W. T. Cocking, 302, Aug.; 347, Sept.; 425, Oct.  
 Long-distance Radio Jubilee, 486, Dec.  
 Loudspeaker Cabinet Design, by D. E. L. Shorter (Correction), 53, Feb.  
 — Diaphragm Control, by J. Moir, 252, July  
 —, Ekco ES115 Extension, 36, Jan.  
 — Input Power, by Thomas Roddam, 29, Jan.  
 —, Ribbon, by P. L. Taylor, 7, Jan.  
 —, Whiteley Concentric Duplex, 36, Jan.  
**MAGNETIC** Dictation Machine, Dictorel, 196, May  
 — Recording Tape, by H. G. M. Spratt, 88, Feb.; 149, Apr.  
 Mains Fluctuations, Countering, by Graham Woodville, 148, Apr.

Mains Transformer, Continuously Variable, by H. E. Styles, 306, Aug.  
 Marconi *Electra* II, 232, June  
 Marconi's Transatlantic Jubilee, 486, Dec.  
 Measuring Instruments Joint Advisory Committee formed (*News*), 412, Oct.  
 Meter, Multi-Range, Taylor Electrical, 519, Dec.  
 — Shunt, Universal, 285, July  
 Meters, Modifying Surplus, by W. H. Cazaly, 376, Sept.  
 Metre-Wave Broadcasting (*Editorials*), 167, May; 209, June; 439, Nov.; (*Correspondence*), 263, July; 500, Dec.  
 Microscopy, Television, 162, Apr.  
 Miniature Walkie-Talkie, 323, Aug.  
 Modern Crystal Set, by B. R. Bettridge, 338, Sept.; (*Correspondence*), 408, Oct.; 457, Nov.; 500, Dec.  
 Modifying "Surplus" Meters, by W. H. Cazaly, 376, Sept.  
 Modulation Battle, A.M. v. F.M., Brit. I.R.E. Paper, 350, Sept.  
 Monitoring, Automatic, (*Correspondence*), 322, Aug.; 457, Nov.  
 Multi-Carrier Air Communications, 92, Mar.  
 Multi-Range Ohmmeter, by I. B. Davidson, 50, Feb.  
 Multiple-Unit Resistors, 292, July  
 Mystery Broadcasting (*Editorial*), 337, Sept.; article by Thomas Roddam, 341, Sept.; (*Correspondence*), 499, Dec.  
**N.P.L.** Open Days, 142, Apr.  
 Navigational Aids, Air, by Basil Clarke, 329, Aug.  
 — Radio on the Airways, 199, May  
 Neon Testers, Grafton, Kerston & Co., 76, Feb.  
 Nerve Communications, I.E.E. paper, 6, Jan.  
 New Daventry Station, by R. W. Hallows, 236, June  
 "Nimrod" Computer, 292, July  
 Nomenclature (*Correspondence*), 321, Aug., 407, Oct.  
**OBITUARY:** Hobday, C. H. G., 462, Nov.; Lay, Arthur W., 139, Apr.; Loring, Comdr. F. G., 462, Nov.; Mallett, Dr. Edward, 55, Feb.; Mansbridge, George F., 182, May; Phillips, Dr. Anton, 462, Nov.  
 Ohmmeter, Multi-Range, by I. B. Davidson, 50, Feb.  
 Operating Airborne Equipment, by Basil B. Clarke, 135, Apr.  
 Oscillators, Phase-Shift (*Correspondence*), 39, Jan.  
 Oscilloscope Calibrator, by W. Tusting, 310, Aug.  
 — "Hum," by W. Tusting, 507, Dec.  
 — Units, Mullard, 37, Jan.  
 Over-Centralization (*Correspondence*), 219, June  
**PARIS** Television Show, by A. V. J. Martin, 459, Nov.  
 Patent Office Library Hours (*News*), 270, July; 503, Dec.  
 Pattern Generator for Television: Radar, Radio and Television Ltd., 269, July  
 Pentode as an Amplifier (*Correspondence*), 369, Sept.  
 Performing Rights (*News*), 183, May  
**PERSONALITIES:** Adorian, Paul, 138, Apr.; Angwin, Sir Stanley, 138, Apr., 225, June; Armstrong, Major Edwin, 314, Aug.; Bareford, Dr. C. F., 314, Aug.; Booker, Dr. H. G., 373, Sept.; Broadbent, J. P., 225, June; Buckle, C., 225, June; Chalk, W. J., 225, June; Clapham, N. C., 138, Apr.; Condliffe, G. E., 503, Dec.; Dannatt, Dr. C., 413, Oct.; Dickson, J. A., 54, Feb.; Dome, R. B., 374, Sept.; Eckersley, T. L., 101, Mar.; Edinburgh H.R.H. The Duke of, 462, Nov.; Edwards, W. G., 413, Oct.; Espley, Dr. D. C., 373, Sept.; Fairfield, C. L. G., 413, Oct.; Fisk, Sir Ernest, 268, July; Fleming, Sir Arthur, 413, Oct.; Fraser, Sir Jan., 268, July; Gilbert, John C. G., 503, Dec.; Gill, Sir Archibald, 413, Oct.; Ginman, A. H., 102, Mar.; Good, Percy, 17, Jan.; Haddon, Sir Richard, 54, Feb.; Heightman, D. W., 102, Mar.; Holmes, R. G. D., 139, Apr.; Howe, Prof. G. W. O., 183, May; Humphreys, O. W., 269, July; Hunt, Harold, 183, May; Hunter, Philip V., 269, July; Hurren, S. A., 503, Dec.; Kirke, H. L., 413, Oct.; Macnamara, T. C., 17, Jan.; McLean, F. C., 413, Oct.; Marler, J. T., 462, Nov.; Maskell, W. A. C., 268, July; Mayo, R. G. E., 269, July;

Mitchell, S. S. C., 503, Dec.; Mumford, A. H., 225, June; Nicholas, Air Comdr. B. D., 17, Jan.; Nicholls, Major General L. R., 138, Apr.; Olson, Dr. Harry F., 314, Aug.; Orr-Ewing, Charles I., 183, May; Pacent, Louis, 139, Apr.; Patrick, R. C., 413, Oct.; Phillips, L. H. J., 102, Mar.; Radley, Dr. W. G., 413, Oct.; Ratcliffe, Prof. John A., 183, May; Reading, Col. J., 413, Oct.; Reed, Dr. Morris, 183, May; Ridgeway, J. W., 102, Mar.; Robertson, N. C., 503, Dec.; Rushforth, Leonard, 54, Feb.; Simpson, T. A., 54, Feb.; Smale, J. A., 373, Sept.; Smith-Rose, Dr. R. L., 138, Apr.; Sowerby, J. McG., 462, Nov.; Spagnoletti, P. H., 138, Apr.; Spencer, Sir Thomas G., 54, Feb.; Stannard, G., 413, Oct.; Stansbridge, S., 413, Oct.; Sugden, G. E., 314, Aug.; Taylor, W. F., 183, May; Turner, L. W., 225, June; Voigt, P. G. A. H., 183, May; Wilkinson, Bruce, 54, Feb.; Zworykin, Dr. V. K., 314, Aug.  
 Phase-Shift Oscillators (*Correspondence*), 39, Jan.  
 Phonetic Alphabets, 512, Dec.  
 Physical Society's Exhibition, 1951 (*News*), 16, Jan.; Survey, 189, Mar.  
 Pickup Design (*Correspondence*), 81, Feb.; 146, Apr.  
 — Input Circuit (*Correspondence*), 40, Jan.  
 Pickups, Intermodulation Distortion in Gramophone, by S. Kelly, 256, July; (*Correspondence*), 370, Sept.  
 Picture-Telegraph Equipment, G.E.C., 36, Jan.  
 Piezoelectric Pickups, B.S.R.A. Paper, 18, Jan.  
 Polar Diagram Plotter, Television Society Paper, 54, Feb.  
 — ? What is a, (*Correspondence*), 220, June  
 Portable, Invieta Mains Battery, 36, Jan.  
 Post Office and Business Radio, 498, Dec.  
 Power-Cut Radio (*Correspondence*), 123, Mar.; (*News*), 462, Nov.; 502, Dec.  
 Printed Circuits, A. H. Hunt Ltd., 163, Apr.  
 Projection Television System, E-lophon, Brit. I.R.E. Paper, 424, Oct.  
**QUARTZ** Crystal Oscillator, Frequency-Modulated, by W. S. Mortley, 399, Oct.  
**R.A.F.** Voluntary Radio Service (*News*), 137, Apr.  
 R.A.M.C. Organization (*News*), 54, Feb.  
 R.E.C.M.F. Exhibition 1951 (*News*), 102, Mar., List of Exhibitors, 134, Apr.; Survey, 185, May; 1952 Show (*News*), 462, Nov.  
 — New Officers (*News*), 184, May  
 — Report on Exports (*News*), 138, Apr.  
 R. F. Chokes, by "Cathode Ray," 494, Dec.  
 R.G.D. Television Receiver L2351T: Test Report, 203, May  
 R.I.C. Premiums for Technical Writing (*Editorial*), 479, Dec.  
 R.N.V.(W)R. Centres (*News*), 54, Feb.  
 R.S.G.B. Convention (*News*), 138, Apr.  
 — Election of Officers (*News*), 139, Apr.  
 — Exhibition (*News*), 183, May; 413, Oct.; 461, Nov.; 503, Dec.  
 — and European Amateurs (*News*), 313, Aug.  
 R.T.E.I. Exam. Results (*News*), 463, Nov.  
 Radar Beginnings (*Correspondence*), 122, Mar.  
 — Claims, Royal Commission on Awards (*News*), 182, May  
 — Display Unit, Decca Type 12, 424, Oct.  
 — Sonds, 155, Apr.  
 Radio and Power Cuts (*News*), 462, Nov.; 502, Dec.  
 — Astronomy, 275, July  
 — Feeder Unit, by J. F. O. Vaughan, 480, Dec.  
 — for Taxis, 491, Dec.  
 — in the Jungle, by "Pronto," 73, Feb.; (*Correspondence*), 179, May  
 — Industries Club Membership and Officers (*News*), 269, July  
 — Industry Council Reconstituted (*News*), 101, Mar.  
 — Officers in Civil Airlines, by Basil R. Clarke, 135, Apr.  
 — Union Officials (*News*), 269, July  
 — on the Airways, 199, May  
 — Re-armament Advisory Committee Formed (*News*), 461, Nov.  
 — Research Board Reports (1933-48), 18, Jan.; (1949), 295, July  
 — Societies and Clubs, List, 19, Jan.; Additions and Amendments, 151, Apr.



Radio Telearchics, 342, Sept.  
 Radiogram, Ace, 36, Jan.  
 — Philips 603A, 75, Feb.  
**RANDOM RADIATIONS**, by "Diallist,"  
 42, Jan.; 77, Feb.; 124, Mar.; 164,  
 Apr.; 206, May; 248, June; 298,  
 July; 334, Aug.; 380, Sept.; 436,  
 Oct.; 476, Nov.; 520, Dec.  
 Receiver, Rainbow 750, 36, Jan.  
 Recording on Tape, by R. W. Lowden, 283,  
 July  
 — Studio Design, by P. A. Shears, 355,  
 Sept.; (*Correspondence*), 458, Nov.  
 Records, Broadcasting of (*Correspondence*),  
 219, June  
 Relay Systems, Rediffusion and Link Sound  
 and Vision, 226, June  
 Resistor Colour Coding (*Correspondence*), 80,  
 Feb.  
 Resistors, Multiple-Unit, 292, July  
 Ribbon Loudspeaker, by P. L. Taylor, 7, Jan.  
 Ringing-Choke E.H.I. Systems, by W. T.  
 Cocking, 444, Nov.; 513, Dec.  
 Royal Society Conversation, 261, July  
 Rugby Station Jubilee (*News*), 102, Mar.  
**S.B.A.C.** Display and Exhibition: Aircraft  
 Radio on Show, 448, Nov.  
 Safety Precautions (*Editorial*), 1, Jan.;  
 article by F. C. Connelly, 2, Jan.;  
 (*Correspondence*), 145, Apr.; F.P.A.  
 Report, 69, Feb.  
 Sampling, by "Cathode Ray," 325, Aug.  
 Science Centre (*News*), 16, Jan.  
 Screen for Cabinets, Acheson Colloids Coated,  
 296, July  
 Screened Valves (*Correspondence*), 408, Oct.  
 See-Saw Circuit, Capacitors in (*Correspondence*),  
 180, May  
 Sensitive Null Detector, by M. G. Scroggie,  
 175, May  
 — T.R.F. Receiver, by S. W. Amos and  
 G. G. Johnstone, 452, Nov.  
 Servicing, Design for, by M. G. Scroggie,  
 396, Oct.  
**SHORT-WAVE CONDITIONS**, by T. W.  
 Bennington, 26, Jan.; 56, Feb.;  
 99, Mar.; 160, Apr.; 205, May;  
 247, June; 288, July; 320, Aug.;  
 375, Sept.; 418, Oct.; 450, Nov.;  
 490, Dec.  
 Signal Generator, Waveforms Ltd., Television,  
 519, Dec.  
 Simple Valve Voltmeter, by S. W. Amos  
 (*Correction*), 53, Feb.  
 Slot Dipole Television Aerial, Indoor, by  
 H. Page, 168, May  
 Soldering Iron, "Néoléc," 297, July  
 — Shunt, Thermal, by P. F. Duncan, 65,  
 Feb.; (*Correspondence*), 220, June  
 Sound Reinforcing, by D. W. Pipe, 117, Mar.  
 — Reproduction (*Editorial*), 251, July  
 Sources of Interference, 468, Nov.  
 Speech Reinforcement Systems, by P. H.  
 Parkin and W. E. Scholes, 44, Feb.  
 Speed of Light, N. E. L. Measurement  
 (*News*), 462, Nov.  
 Square-Law Rectifier Voltmeter, by Thomas  
 Roddam, 316, Aug.  
 — Wave Generator, by O. C. Wolls, 35,  
 Jan.; (*Correction*), *News* 103, Mar.;  
 (*Correspondence*), 322, Aug.  
 — Shaper, Wide-Range, by J. E.  
 Attew, 517, Dec.  
 Stabilizing Feedback Amplifiers, by Thomas  
 Roddam, 112, Mar.  
 Standard Frequencies, N. P. L. Revised  
 Schedule (*News*), 501, Dec.  
 — Frequency Transmissions, 378, Sept.  
 Standardized Chassis, B.B.C. Design, 261,  
 July  
 Stereophonic Sound, by J. Moir, 84, Mar.;  
 (*Correspondence*), 145, Apr.  
 Stereophony on Television Channels, 371,  
 Sept.  
 Studio Acoustics, B.B.C. Measurement, 435,  
 Oct.

Studio Design, Recording, by P. A. Shears,  
 355, Sept.; (*Correspondence*), 458, Nov.  
 Sunderland Radar Installation, 34, Jan.  
 Suppressors, Wolf Electric Drill, 379, Sept.  
**T.I.D.U.** now part of D.S.I.R. (*News*), 183,  
 May  
 T.R.F. Receiver, Sensitive, by S. W. Amos and  
 G. G. Johnstone, 452, Nov.  
 T-Match Television Aerial, by B. Mayson,  
 404, Oct.  
 Tape Recorder Unit, Fidelity, 475, Nov.  
 — Recording, by R. W. Lowden, 283, July  
 — Heads, Bradmatic, 119, Mar.  
 — — — Fidelity Magnetic Products,  
 119, Mar.  
 Taxi Radio, 491, Dec.  
 Technical Writing Premiums (*Editorial*),  
 479, Dec.  
 Telearchics, Radio, 342, Sept.  
 — on Show, *Model Engineer* Exhibition,  
 433, Oct.  
 Telecommunications Research, D.S.I.R., 431,  
 Oct.  
 Telekinema Stereophonic Sound, 223, June  
 — Demonstrations, (*Correspondence*), 264,  
 July; (*Editorial*), 301, Aug.  
 Telescribe in Civil Aviation, 512, Dec.  
 Television Advisory Committee (*News*), 374,  
 Sept.  
 — Aerial Aesthetics (*Correspondence*), 40,  
 Jan.  
 — Aerials 218, June  
 — Aerialite Fringe-Area, 53, Feb.  
 — and Sound by Wire, by R. I. Kinross,  
 126, Apr.  
 — Colour Coding (*Correspondence*), 80,  
 Feb.  
 — Fire Hazard (*Editorial*), 1, Jan.;  
 article by F. C. Connelly, 2, Jan.;  
 (*Correspondence*), 145, Apr.  
 — Licences Payment (*Correspondence*), 220,  
 June  
 — Mains Load (*Correspondence*), 39, Jan.  
 — Microscopy, 162, Apr.  
 — O.B. Units for U.B.C. (*News*), 501, Dec.  
 — Radio Links, Emitron, 406, Oct.  
 — Receiver, G.E.C. BT5144, 75, Feb.  
 — — — Philips 1502U, 163, Apr.  
 — — — R.G.D. L2351T: Test Report,  
 203, May  
 — Receivers, Valradio Projection, 75,  
 Feb.  
 — Regress (*News*), 182, May  
 — Relay Loss (*Correspondence*), 145, Apr.;  
 180, May; 220, June  
 — — — Systems, Rediffusion and Link  
 Sound and Vision, 226, June  
 — Society Exhibition (*News*), 501, Dec.  
 — Visor (*Correspondence*), 122, Mar.  
 — Zoom Lens, 312, Aug.  
 Temporary Vision Aerial, by F. D. Bolt,  
 13, Jan.  
 Temperature Fuses, 295, July  
 Tens or Twos? by "Cathode Ray," 351,  
 Sept.  
 Testing Steep-Slope Valves, by J. C. Finlay,  
 108, Mar.  
 That Other Valve Equivalent, by "Cathode  
 Ray," 152, Apr.  
 Thermal Soldering Shunt, by P. F. Duncan,  
 65, Feb.; (*Correspondence*), 220, June  
 Thorn Needles (*Correspondence*), 121, Mar.;  
 145, Apr.  
 1,000-Line Will o' the Wisp, by R. W.  
 Hallows, 197, May; (*Correspondence*),  
 322, Aug.  
 Tolerances and Errors (*Correspondence*), 41,  
 Jan.  
 Training Technicians and Technologists,  
 Govt. and Industry Proposals, 136,  
 Apr.  
 Transatlantic Tests, 1921, 100, Mar.  
 Transformer, Continuously Variable Mains,  
 by H. E. Styles, 306, Aug.  
 — — — John Bell and Croyden Miniature,  
 37, Jan.; (*Correction*), 119, Mar.

Transformers, Philips Variable Mains, 119,  
 Mar.  
 Transportable Receiver, Pye P43U, 163,  
 Apr.  
 Trends in Components, R.E.C.M.F. Exhibi-  
 tion, 185, May  
 Trimming Capacitors, Erie Resistor, 297,  
 July  
 Tuner Unit, Chapman Reproducers, 379,  
 Sept.  
**U.S.** Colour Television, 107, Mar.; (*News*),  
 314, Aug.  
 Ultrasonic Soldering Bath, Mullard, 379,  
 Sept.  
**UNBIASED**, by "Free Grid," 38, Jan.; 78,  
 Feb.; 120, Mar.; 166, Apr.; 208,  
 May; 250, June; 300, July; 336,  
 Aug.; 382, Sept.; 438, Oct.; 478,  
 Nov.; 522, Dec.  
 Unit of Sensitivity, 472, Nov.  
 — — — Capacitance: Legitimizing the  
 "Puff" (*Correspondence*), 321, Aug.;  
 407, Oct.; 458, Nov.; 499, Dec.  
 Universal Meter Shunt, 285, July  
 Unusual Ladder Filter, by F. G. G. Davey,  
 31, Jan.  
**V.H.F.** Civil Aviation Communications, 92,  
 Mar.  
 — Direction Finder, Marconi (*News*), 502,  
 Dec.  
 — Transmitter, Plessey PT15, 75, Feb.  
 Valve Cathode Life, by C. C. Eaglesfield, 505,  
 Dec.  
 — — — How to Choose a, by Thomas Roddam,  
 221, June; (*Correction*), 324, Aug.  
 — Making, Brit. I.R.E. Convention (*News*),  
 373, Sept.; (*Correspondence*), 500, Dec.  
 — Priorities (*Correspondence*), 370, Sept.  
 — Symbols (*Correspondence*), 179, May  
 — Voltmeter, Audio-Frequency, by S.  
 Kelly, 215, June  
 Vector Diagrams, by "Cathode Ray," 22,  
 Jan.; 61, Feb.; 95, Mar.; (*Correction*),  
 139, Apr.  
 "Voltage": E.M.F. or P.D.? (*Correspondence*),  
 79, Feb.  
 Voltmeter, Square-Law Rectifier, by Thomas  
 Roddam, 316, Aug.  
 — — — Valve Audio-Frequency, by S. Kelly,  
 215, June  
**WALKIE-Talkie**, Pye Miniature, 323, Aug.  
 — — — New American, 291, July  
 Waterworks Radio, Ekeco, 332, Aug.  
 Wattage: Redundant Word? (*Correspondence*),  
 458, Nov.; 499, Dec.  
 Wave Analyser, Edison Swan, 36, Jan.  
 Wavelength Problem: Is Sampling the  
 Answer? by "Cathode Ray," 325,  
 Aug.  
 Wenvoe Television Station (*News*), 102, Mar.  
 Wide-Band Flexible Aerials, 243, June  
 — Range Square-Wave Shaper, by J. E.  
 Attew, 517, Dec.  
 Wire Distribution System, Television and  
 Sound, by R. I. Kinross, 126, Apr.  
 — Recorder, Angel Scientific Products,  
 76, Feb.  
 Wireless World Television Receiver, Further  
 Notes on, 286, July  
**WORLD OF WIRELESS**, 15, Jan.; 54,  
 Feb.; 101, Mar.; 137, Apr.; 182, May;  
 224, June; 268, July; 313, Aug.;  
 372, Sept.; 412, Oct.; 461, Nov.;  
 501, Dec.  
 Wrotham Aerial System, by C. Gillam, 210,  
 June; 279, July  
 — Transmitting Station, 141, Apr.  
**YOUR** Loudspeaker, by Thomas Roddam,  
 29, Jan.  
**ZIRCONIUM**, Murex, 164, Apr.  
 Zworykin Prize (*News*), 183, May

## CLASSIFIED INDEX

(All entries except Books, Illustrations and Authors also appear in the General Index.)

### AERIALS

Helical Aerial, General Electric, America,  
 262, July  
 Indoor Television Aerial, by H. Page, 168,  
 May  
 Polar Diagram Plotter, 84, Feb.  
 T-Match Television Aerial, by B. Mayson,  
 404, Oct.  
 Television Aerial Aesthetics (*Correspondence*),  
 40, Jan.  
 — Aerials, 218, June  
 Temporary Vision Aerial, by F. D. Bolt, 13,  
 Jan.

Wide-band Flexible Aerials, 243, June  
 Wrotham Aerial System, by C. Gillam, 210,  
 June; 279, July

### CIRCUITRY

Amplified Automatic Gain Control, by  
 S. W. Amos and G. G. Johnstone,  
 415, Oct.; T.R.F. Receiver, 452, Nov.  
 Capacitors in See-Saw Circuit (*Correspondence*),  
 180, May  
 Cathode Follower Circuit (*Correspondence*),  
 180, May; 220, June

Diodes for Drift Correction (*Correspondence*),  
 80, Feb.  
 Efficiency Line-Scan Circuits, by W. T.  
 Cocking, 302, Aug.; 347, Sept.;  
 425, Oct.  
 FMQ, by W. S. Mortley, 399, Oct.  
 Limiter Circuit: Ignition Interference Sup-  
 pressor, by Ronald G. Young, 451  
 Nov.  
 Nomenclature (*Correspondence*), 321, Aug.  
 407, Oct.  
 Phase Shift Oscillators (*Correspondence*), 39,  
 Jan.

Square-Law Rectifier Voltmeter, by Thomas Roddam, 316, Aug.  
Stabilizing Feedback Amplifiers, by Thomas Roddam, 112, Mar.  
T.R.F. Receiver, by S. W. Amos and G. G. Johnstone, 452, Nov.  
That Other Valve Equivalent, by "Cathode Ray," 152, Apr.  
Unusual Ladder Filter, by F. G. G. Davey, 31, Jan.

#### DESIGN

Audio-Frequency Valve Voltmeter, by S. Kelly, 215, June  
Band-pass Converters, by H. B. Dent, 67, Feb.  
Continuously Variable Mains Transformer, by H. E. Styles, 306, Aug.  
Crystal Set, Modern, by B. R. Bettridge, 338, Sept.; (*Correspondence*), 408, Oct.; 457, Nov.; 500, Dec.  
E.H.F. from an R.F. Oscillator, by C. J. Dickinson, 70, Feb.  
Electronic Fluxmeter, by P. L. Taylor, 161, Apr.  
F.M. Receiver, by J. G. Spencer, 440, Nov.; 487, Dec.  
Flyback E.H.T. Booster, by A. H. B. Walker, 27, Jan.  
Indoor Television Aerial, by H. Page, 168, May  
Modifying "Surplus" Meters, by W. H. Cazaly, 376, Sept.  
Multi-Range Ohmmeter, by I. B. Davidson, 50, Feb.  
Multiple-Unit Resistors, 292, July  
Oscilloscope Calibrator, by W. Tusting, 310, Aug.  
Radio Feeder Unit, by J. F. O. Vaughan, 480, Dec.  
Ribbon Loudspeaker, by P. L. Taylor, 7, Jan.  
Sensitive Null Detector, by M. G. Scroggie, 175, May  
— T.R.F. Receiver, by S. W. Amos and G. G. Johnstone, 452, Nov.  
Square-Wave Generator, by O. C. Wells, 35, Jan.; (*Correction*), 103, Mar.; (*Correspondence*), 322, Aug.  
T-Match Television Aerial, by B. Mayson, 404, Oct.  
Thermal Soldering Shunt, by P. F. Duncan, 65, Feb.; (*Correspondence*), 220, June  
Wide-Range Square-Wave Shaper, by J. E. Atlew, 517, Dec.  
*Wireless World* Television Receiver, Further Notes on, 286, July

#### ELECTRONICS

Attenuation of Screened Rooms. E.R.A. Report, 151, Apr.  
Computer, New Digital, 353, Aug.  
— "Nimrod," 292, July  
Computers, by "Cathode Ray," 419, Oct.; (*Correspondence*), 458, Nov.; 499, Dec.  
Electronic Flight Simulator, 130, Apr.  
— Photography, Mullard, 87, Mar.  
Radio Telecharts, 342, Sept.  
Square-Wave Generator, by O. C. Wells, 35, Jan.; (*Correction*), 103, Mar.; (*Correspondence*), 322, Aug.  
Telecharts on Show, *Model Engineer* Exhibition, 433, Oct.  
Telescribe in Civil Aviation, 512, Dec.

#### MANUFACTURERS' PRODUCTS

Ace Radiogram, 36, Jan.  
Acheson Colloids Coated Screen for Cabinets, 296, July  
Aerialite Fringe-Area Television Aerials, 53, Feb.  
Amplion "Activette" for Dry Batteries, by R. W. Hallows, 434, Oct. (*Correspondence*), 457, Nov.  
Amphivox Miniature Hearing Aid, 296, July  
Angel Scientific Products Wire Recorder, 76, Feb.  
Bell & Croyden Miniature Transformer, 37, Jan.; (*Correction*), 119, Mar.  
Bonochoord Miniature Earphone, 475, Nov.  
— Miniature Hearing Aid, 37, Jan.  
Bradmatic Tape-Recording Heads, 119, Mar.  
Clapman Reproducers' Radio Tuner Unit, 379, Sept.  
Decca, Harbour-Control Radar, 105, Mar.; (*Correspondence*), 220, June  
Denco Miniature Coil Turrets, 519, Dec.  
Dietorel Magnetic Dictation Machine, 196, May  
Eddystone Amateur Beam Aerial, 475, Nov.  
Edison Swan Analyser, 36, Jan.  
Ekco ES115 Extension Loudspeaker, 36, Jan.  
English Electric Steel C.R. Tubes (*News*), 16, Jan.  
Erie Trimming Capacitors, 297, July

Exide Unspillable LPM4 Accumulator, 119, Mar.  
G.E.C. BT5144 Television Receiver, 75, Feb.  
— C.B. Tubes for Television, 297, July  
— Germanium Rectifier, 37, Jan.  
— Picture-Telegraph Equipment, 36, Jan.  
Grafton, Kerston & Co., Neon Testers, 76, Feb.  
Hunt Printed Circuits, 163, Apr.  
Invicta A.C./D.C. Battery Portable, 36, Jan.  
Marconi V.H.F. Direction Finder (*News*), 502, Dec.  
Maurice Equipment Co's Circular Indoor Aerial, 218, June  
Merryweather O.B. Mobile Aerial, 75, Feb.  
Metal Processes, Imitation Nickel Plating, 460, Nov.  
Miniature Bearings Ball Race, 296, July  
Mullard Oscilloscope Units, 37, Jan.  
— Telescribe, 512, Dec.  
— Ultrasonic Soldering Bath, 379, Sept.  
Murex Zirconium, 164, Apr.  
Murphy Cylindrical Chassis, 324, Aug.  
— Neoflex "Soldering Iron, 297, July  
Phidellity Tape Recorder Unit, 475, Nov.  
Philips 603A Radiogram, 75, Feb.  
— 1502 U Television Receiver, 163, Apr.  
— Variable Mains Transformers, 119, Mar.  
Plessey Aerial Multicoupler, 36, Jan.  
— PT15 V.H.F. Transmitter, 75, Feb.  
Pye Miniature Crystal Oven, 163, Apr.  
— Miniature Walkie-Talkie, 323, Aug.  
— P43U Transportable Receiver, 163, Apr.  
R.G.D. Television Receiver L2351T: Test Report, 203, May  
Radar, Radio & Television Ltd., Pattern Generator, 296, July  
Rainbow 750 Receiver, 36, Jan.  
Scott Bader Potted Circuits, 493, Dec.  
Taylor Electrical Multi-Range Meter, 519, Dec.  
Telcon Transmitter Feeder Cable, 37, Jan.  
Valradio Projection Television Receivers, 75, Feb.  
Waveforms Ltd. Television Signal Generator, 519, Dec.  
Whiteley 12-in Concentric Duplex Loudspeaker, 36, Jan.  
Wolf Electric Drill Suppressors, 379, Sept.

#### MISCELLANEOUS

American Insularity (*Correspondence*), 179, May  
Dimensions, by "Cathode Ray," 469, Nov.  
E.M.F. or P.D.? (*Correspondence*), 79, Feb.  
Electrical Dangers (*Correspondence*), 80, Feb.; 180, May  
Electrolytic Capacitors, by G. W. A. Dummer, 510, Dec.  
Ferié—Unit of Sensitivity, 472, Nov.  
Grouped Component References, by L. Bainbridge-Bell, 115, Mar.; (*Correspondence*), 219, June  
Joining Aluminium, 181, May; (*Correspondence*), 408, Oct.; 500, Dec.  
Legitimizing the "Puff" (*Correspondence*), 321, Aug.; 407, Oct.; 468, Nov.; 499, Dec.  
R.F. Chokes, by "Cathode Ray," 494, Dec.  
Re-activating Dry Batteries, by R. W. Hallows, 434, Oct.; (*Correspondence*), 457, Nov.  
Standardized Chassis, B.B.C. Design, 261, July  
Temperature Fuses, 295, July  
Vector Diagrams, by "Cathode Ray," 22, Jan.; 61, Feb.; 95, Mar.; (*Correction*), 139, Apr.

#### MODULATION

A.M. versus F.M. (*Correspondence*), 39, Jan.; 79, Feb.; 122, Mar.; 146, Apr.; 220, June; 263, July; 407, Oct.; 458, Nov.; (*Editorials*), 167, May; 209, June; Brit. I.R.E. Paper, 350, Sept.; (*News*), 372, Sept.  
E.H.F. Communications (*Correspondence*), 122, Mar.  
FMQ, by W. S. Mortley, 399, Oct.  
F.M. and Exports (*Correspondence*), 322, Aug.  
Frequency Modulation, by "Cathode Ray," 193, May; 239, June; 271, July; (*Corrections*), 325, Aug.  
Industry and E.H.F. (*Correspondence*), 263, July  
Mystery Broadcasting (*Editorial*), 337, Sept.; article by Thomas Roddam, 341, Sept.; (*Correspondence*), 499, Dec.  
Sampling, by "Cathode Ray," 325, Aug.  
Stereophony on Television Channels, 371, Sept.  
Wrotham Transmitting Station, 141, Apr.

#### ORGANIZATION

Airmet (*News*), 102, Mar.  
Amateur F.M. and Television Frequencies (*News*), 313, Aug.; 319, Aug.; 461, Nov.  
— Radio Developments, by J. P. Hawker, 465, Nov.  
B.B.C. Stations, List of, 104, Mar.  
B.S.I. Committee's Report (*News*), 138, Apr.  
— Jubilee Exhibition (*News*), 182, May  
B.S.R.A. Exhibition, 182, May; 265, July; Convention, 260, July; Officers, 374, Sept.  
B.V.A. Officers (*News*), 413, Oct.  
Bad Radio Teaching (*Correspondence*), 500, Dec.  
Brit. I.R.E. Annual Meeting and Officers (*News*), 461, Nov.; Graduateship Exam. (*News*), 139, Apr.; 1951 Convention (*News*), 101, Mar.; 138, Apr.; 224, June; 268, July; 314, Aug.; 372, Sept.  
Business Radio, P.M.G.'s Statement (*News*), 372, Sept.; 412, Oct.  
— Radio, Details of Service, 498, Dec.  
Cinema Television (*Editorial*), 83, Mar.  
Copenhagen and Intermediate Frequencies, 360, Sept.  
D.S.I.R. Telecommunications Research, 421, Oct.  
Europe's V.H.F. Stations (*News*), 137, Apr.  
F.M. and Exports (*Correspondence*), 322, Aug.  
— in Germany (*News*), 463, Nov.  
G.R.S.E.-War Office Agreement (*News*), 139, Apr.  
High-Definition Films Ltd., Company Formed (*News*), 502, Dec.  
I.E.E. Joint Engineering Conference (*News*), 224, June; Annual Report (*News*), 269, July; Premiums (*News*), 373, Sept.; Council (*News*), 374, Sept.; Radio Section Committee (*News*), 374, Sept.; 1952 Television Convention (*News*), 138, Apr.; 412, Oct.  
I.F. Problems (*News*), 15, Jan.; 360, Sept.  
I.P.R.E. North-Eastern Section Formed (*News*), 139, Apr.  
I.S.W.C. Competitions (*News*), 17, Jan.  
Institute of Physics Annual Report (*News*), 269, July; Graduateship Exam. (*News*), 412, Oct.  
Interference Suppression: Good Example (*Correspondence*), 80, Feb.  
International Conference at Geneva (*News*), 372, Sept.  
Italian F.M. (*News*), 15, Jan.  
Measuring Instruments, Joint Advisory Committee Formed (*News*), 412, Oct.  
Multi-Carrier Air Communications, 92, Mar.  
Operating Airborne Equipment, by Basil R. Clarke, 135, Apr.  
Performing Rights (*News*), 183, May  
Phonetic Alphabets, 512, Dec.  
Physical Society Exhibition (*News*), 16, Jan.  
Post Office Report for 1950, 255, July  
R.A.F. Voluntary Radio Service (*News*), 137, Apr.  
R.E.C.M.F. 1951 Exhibition (*News*), 102, Mar.; 134, Apr.; Officers (*News*), 184, May; 1952 Exhibition (*News*), 462, Nov.  
R.S.G.B. Convention (*News*), 138, Apr.; Officers (*News*), 139, Apr.; Exhibition (*News*), 183, May  
R.T.E.B. Exam. Results (*News*), 463, Nov.  
Radio and Power Cuts (*News*), 462, Nov.; 502, Dec.  
— Industry Council's Committee (*News*), 101, Mar.  
— Industries Club Membership and Officers (*News*), 269, July  
— Officers' Union Officials (*News*), 269, July  
— Re-armament Advisory Committee Formed (*News*), 461, Nov.  
— Research Board Reports (1933-46), 18, Jan.; (1949), 295, July  
— Societies and Clubs, List, 19, Jan.; Additions and Amendments, 151, Apr.  
Resistor Colour Coding (*Correspondence*), 80, Feb.  
Standard Frequencies Revised (*News*), 501, Dec.  
T.I.D.U. now part of D.S.I.R. (*News*), 183, May  
Telekinema Demonstrations (*Correspondence*), 264, July; (*Editorial*), 301, Aug.  
Television Advisory Committee (*News*), 374, Sept.  
— Licences Payment (*Correspondence*), 220, June  
Training Technicians and Technologists, Govt. and Industrial Reports, 136, Apr.  
Wireless Telegraphy Act 1949, P.M.G.'s Statement (*Editorial*), 337, Sept.



## PROPAGATION

- Ionosphere Review : 1950, by T. W. Bennington, 109, Mar.  
Radio Astronomy, 275, July  
Radio in the Jungle, by "Pronto," 73, Feb.; (Correspondence), 179, May

## RADIOLOCATION

- Air Navigational Aids, by Basil Clarke, 329, Aug.  
Airfield Surface Movement Indicator, 170, May  
Automatic Course Plotting, 143, Apr.; (News), 501, Dec.  
Harbour Control Radar, 105, Mar.; (Correspondence), 220, June  
Radar Beginnings (Correspondence), 122, Mar.  
— Claims, Royal Commission on Awards (News), 182, May  
— Display Unit, Decca Type 12, 424, Oct.  
— Sonde, 155, Apr.  
Radio Astronomy, 275, July  
— on the Airways, 199, May  
Sunderland Radar Installation, 34, Jan.

## SOUND REPRODUCTION

- Acoustics of the Royal Festival Hall, 244, June  
Air Traffic Control Records (Correspondence), 123, Mar.  
Amplified Automatic Gain Control, by S. W. Amos and G. G. Johnstone, 415, Oct.; T.R.F. Receiver, 452, Nov.  
Amplifiers for Disc Recording, B.S.R.A. Lecture, 14, Jan.  
Approach to "High Fidelity," 289, July  
Association of Professional Recording Studios, Presidential Address, 12, Jan.  
— Public Address Engineers' Exhibition, 259, 265, July; (News), 182, May  
Audio Convention, Brit. I.R.E., 409, Oct.  
Automatic Monitoring (Correspondence), 322, Aug.; 457, Nov.  
B.B.C./G.P.O. Standards (Correspondence), 263, July; 369, Sept.  
Bass without Big Battles, by K. A. Exley, 132, Apr.; (Correspondence), 219, May; 264, July; 321, Aug.; 369, Sept.; 408, Oct.  
Broadcasting of Records (Correspondence), 219, June  
Continental Gramophone Records, 484, Dec.  
Distribution of Sound (Editorial), 43, Feb.  
Electromagnetic Gramophone Pickups, B.S.R.A. paper, 238, June  
Festival Hall Acoustics, 244, June  
Frequency Test Records, B.S.R.A. discussion, 231, June  
Gramophone Turntable Speeds, by G. F. Dutton, 227, June  
Hearing Aid Problems, Brit. I.R.E. paper, 107, Mar.  
Home Broadcast Recording, Beveridge Report (Editorial), 125, Apr.  
House of Lords, Tannoy Installation, 312, Aug.  
Intermodulation Distortion in Gramophone Pickups, by S. Kelly, 256, July; (Correspondence), 370, Sept.  
— Testing, by E. W. Berth-Jones, 233, June  
Loudspeaker Design, Progress in, Brit. I.R.E. paper, 18, Jan.  
— Diaphragm Control, by J. Moir, 252, July  
— Input Power, by Thomas Roddam, 29, Jan.  
Magnetic Dictation Machine, Dictorel, 196, May  
— Recording Tape, by H. G. M. Spratt, 88, Feb.; 149, Apr.  
Pickup Design (Correspondence), 81, Feb.; 146, Apr.  
— Input Circuit (Correspondence), 40, Jan.  
Piezoelectric Pickups, B.S.R.A. paper, 18, Jan.  
Recording on Tape, by R. W. Lowden, 283, July  
— Studio Design, by P. A. Shears, 355, Sept.; (Correspondence), 458, Nov.  
Ribbon Loudspeaker, by P. L. Taylor, 7, Jan.  
Sound Reinforcing, by D. W. Pipe, 117, Mar.  
— Reproduction (Editorial), 251, July  
Speech Reinforcement Systems, by P. H. Parkin and W. E. Scholes, 44, Feb.  
Stabilizing Feedback Amplifiers, by Thomas Roddam, 112, Mar.  
Stereophonic Sound, by J. Moir, 84, Mar.; (Correspondence), 145, Apr.

- Stereophonic Sound in the Telekinema, 223, June  
Stereophony on Television Channels, 371, Sept.  
Studio Acoustics, B.B.C. Measurement, 435, Oct.  
Thorn Needles (Correspondence), 121, Mar.; 145, Apr.

## TELEVISION

- Aluminizing Cathode-Ray Tubes, by S. R. Neuberger and J. H. Jupe, 245, June  
Amateur Television, 313, 319, Aug.; 461, Nov.  
— Dutch Frequencies (News), 102, Mar.  
American Coast-to-Coast Television (News), 461, Nov.  
— Colour Television, 107, Mar.; (News), 314, Aug.  
— High-Definition Television, 156, Apr.  
British Amateur Television Club Convention (News), 225, June; 319, Aug.  
Cinema Television (Editorial), 83, Mar.  
Countering Mains Fluctuations, by Graham Woodville, 148, Apr.  
Cylindrical Chassis, Murphy, 324, Aug.  
Danish Television (News), 463, Nov.  
Dutch Television (News), 101, Mar.; 462, Nov.  
E.H.T. from an R.F. Oscillator, by C. J. Dickinson, 70, Feb.  
Efficiency Line-Scan Circuits, by W. T. Cocking, 302, Aug.; 347, Sept.; 425, Oct.  
Eidophor Projection Television System, Brit. I.R.E. Convention Paper, 424, Oct.  
Festival Demonstrations, Telekinema, (Correspondence), 264, July; (Editorial), 301, Aug.  
Flyback E.H.T. Booster, by A. H. B. Walker, 27, Jan.  
French Television (News), 225, June  
German Television (News), 412, Oct.  
Holme Moss Television Station Opens, 473, Nov.; Tests (News), 313, Aug.  
Ignition Interference Suppressor, by Ronald G. Young, 451, Nov.  
Indoor Television Aerial, by H. Page, 168, May  
Interference Suppression: Good Example (Correspondence), 80, Jan.  
Mains Load (Correspondence), 39, Jan.  
O.B. Units for C.B.C. (News), 601, Dec.  
Paris Television Show, by A. V. J. Martin, 459, Nov.  
R.G.D. Television Receiver, L2351T: Test Report, 203, May  
Relay Loss, Television (Correspondence), 145, Apr.; 180, May; 220, June  
— Systems, Redifusion and Link, Sound and Vision, 226, June  
Ringing-Choke E.H.T. Systems, by W. T. Cocking, 444, Nov.; 513, Dec.  
Stereophony on Television Channels, 371, Sept.  
T-Match Television Aerial, by B. Mayson, 404, Oct.  
Television Aerial Aesthetics (Correspondence), 40, Jan.  
— Aerials, 218, June  
— and Sound by Wire, by R. I. Kinross, 126, Apr.  
— at South Bank, 244, June  
— Colour Coding (Correspondence), 80, Feb.  
— Microscopy, 162, Apr.  
— Radio Links, Emitron, 406, Oct.  
— Visor (Correspondence), 122, Mar.  
Temporary Vision Aerial, by F. D. Bolt, 13, Jan.  
1,000-Line Will of the Wisp, by R. W. Hallows, 197, May; (Correspondence), 322, Aug.  
Wenvoe Television Station (News), 102, Mar.  
Wireless World Television Receiver, Further Notes on, 286, July  
Zoom Lens, 312, Aug.

## TEST AND MEASUREMENT

- Audio-Frequency Valve Voltmeter, by S. Kelly, 215, June  
C.R.T. Luminous Phenomena: Curious Effect (Correspondence), 40, Jan.  
Electronic Fluxmeter, by P. L. Taylor, 161, Apr.  
Intermodulation Distortion in Gramophone Pickups, by S. Kelly, 256, July; (Correspondence), 370, Sept.  
— Testing, by E. W. Berth-Jones, 233, June  
Modifying Surplus Meters, by W. H. Cazaly, 376, Sept.

- Multiple-Unit Resistors, 292, July  
Multi-Range Ohmmeter, by I. B. Davidson, 50, Feb.  
Oscilloscope Calibrator, by W. Tusting, 310, Aug.  
— "Hum," by W. Tusting, 507, Dec.  
Polar Diagram Plotter, 84, Feb.  
Sensitive Null Detector, by M. G. Scroggie, 175, May  
Square-Law Rectifier Voltmeter, by Thomas Roddam, 316, Aug.  
Studio Acoustics, B.B.C. Measurement, 435, Oct.  
Test and Measuring Gear at Physical Society's and R.E.C.M.F. Exhibitions, 191, May  
Testing Steep-Slope Valves, by J. C. Finlay, 103, Mar.  
Tolerances and Errors (Correspondence), 41, Jan.  
Universal Meter Shunt, 285, July  
Wide-Range Square-Wave Shaper, by J. E. Atwell, 517, Dec.

## TRANSMISSION

- A.M. versus F.M. (Correspondence), 39, Jan.  
79, Feb.; 122, Mar.; 146, Apr.; 220, June; 263, July; 407, Oct.; 458, Nov.; (Editorials), 107, May; 209, June; Brit. I.R.E. Paper, 350, Sept.; (News), 372, Sept.  
Amateur Radio Developments, by J. P. Hawker, 465, Nov.  
B.B.C./G.P.O. Standards (Correspondence), 263, July; 369, Sept.  
Davenport Station, New, by R. W. Hallows, 236, June  
E.H.F. Communications (Correspondence), 122, Mar.  
FMQ, by W. S. Mortley, 399, Oct.  
High-Definition Television, U.S., 156, Apr.  
Holme Moss Television Station Opens, 473, Nov.; Tests (News), 313, Aug.  
Industry and E.H.F. (Correspondence), 263, July  
Metre-Wave Broadcasting (Editorials), 167, May; 209, June; 439, Nov.; (Correspondence), 263, July; 500, Dec.  
Multi-Carrier Air Communications, 92, Mar.  
Mystery Broadcasting (Editorial), 337, Sept.; article, by Thomas Roddam, 341, Sept.; (Correspondence), 499, Dec.  
Nerve Communications, I.E.E. Paper, 6, Jan.  
Radio for Taxis, 491, Dec.  
Sampling, by "Cathode Ray," 325, Aug.  
Standard Frequency Transmissions, 378, Sept.  
Stereophony on Television Channels, 371, Sept.  
Television and Sound by Wire, by R. I. Kinross, 126, Apr.  
— Radio Links, Emitron, 406, Oct.  
Temporary Vision Aerial, by F. D. Bolt, 13, Jan.  
Walkie-Talkie, New American, 291, July  
— Pye Miniature, 323, Aug.  
Waterworks Radio, Ekco, 332, Aug.  
Wrotham Aerial System, by C. Gillam, 210, June; 279, July  
— Transmitting Station, 141, Apr.

## VALVES AND THERMIONICS

- Aluminizing Cathode-Ray Tubes, by S. R. Neuberger and J. H. Jupe, 245, June  
Countering Mains Fluctuations, by Graham Woodville, 148, Apr.  
Diode Detector Distortion, by W. T. Cocking, 171, May  
Gas Discharge Tubes, 293, July  
Germanium Diodes, by R. T. Lovelock and J. H. Jupe, 57, Feb.  
How Reliable is a Radio Valve?, I.E.E. discussion, 91, Mar.  
How to Choose a Valve, by Thomas Roddam, 221, June; (Correction), 324, Aug.  
Klystron, High-Power, 354, Sept.  
Pendule, the Innocent (Correspondence), 360, Sept.  
Screened Valves (Correspondence), 408, Oct.  
Steel C.R. Tubes, English Electric, (News), 16, Jan.  
That Other Valve Equivalent, by "Cathode Ray," 152, Apr.  
Valve and Circuit Noise, Radio Research Report, 129, Apr.  
— Cathode Life, by C.C. Eaglesfield, 505, Dec.  
— Making, Brit. I.R.E. Convention (News), 373, Sept.; (Correspondence), 500, Dec.  
— Priorities (Correspondence), 370, Sept.  
— Symbols (Correspondence), 179, May

**BOOKS**

A.C./D.C. Test Meters, W. H. Cazaly and Thomas Roddam (*Review*), 294, July  
**A.R.R.L. Handbook**, 1951, 305, Aug.  
 Adventure in Vision, John Swift, 66, Feb.  
 Applied Electricity, Edward Hughes, 196, May  
 Atoms and Atomic Energy, R. W. Hallows, 66, Feb.  
 Attenuation of Screened Rooms, E.R.A. Report M/T104, 151, Apr.  
 B.A. Screws, BS57 (*News*), 314, Aug.  
 B.B.C. 1950/1 Report, H.M.S.O. (*News*), 461, Nov.  
 B.B.C. Year Book 1952 (*News*), 502, Dec.; 521, Dec.  
 B.S.I. Committee's Report (*News*), 138, Apr.  
 B.S.R.A. Diary (*News*), 103, Mar.  
 British Radio, R.I.C. Booklet (*News*), 269, July  
 British Standard for Dry Batteries for Domestic Receivers, BS1766: 1951, 506, Dec.  
 British Standards Year Book, (*News*), 414, Oct.  
 Broadcasting: Memorandum on the Report of the Broadcasting Committee, 1949, H.M.S.O. (*Editorial*), 301, Aug.  
 Certification and Licensing of Aircraft Radio Personnel (*News*), 269, July  
 Communications Receiving Equipment (*News*), 184, May  
 Component Specifications, R.I.C., 238, June; 294, July, 484, Dec.  
 Cours Complet pour la Formation Technique des Radios Militaires et Civils, Georges Ginioux, 66, Feb.  
 Education and Training of Electrical Technicians, 136, Apr.  
 Electronic Photographic Speedlamp, John Harrison, 66, Feb.  
 Explaining Television, R.T.R.A. Booklet (*News*), 103, Mar.  
 Facts and Figures, B.S.R.A., 503, Dec.  
 Fire Research 1950, D.S.I.R. (*News*), 462, Nov.  
 Future Development of Higher Technological Education, 136, Apr.  
 Glossary of Terms used in Telecommunication BS204 (*News*), 414, Oct.  
 Graphical Symbols used in Waveguide Technique, BS530: 1948, Supp. No. 2 (*News*), 414, Oct.  
 Grommets for General Purposes, BS1767: 1951 (*News*), 503, Dec.  
 Guide to Broadcasting Stations (*News*), 373, Sept.  
 Heaviness Centenary Volume, I.E.E., 28, Jan.  
 How to Listen to the World, O. Lund Johansen, 60, Feb.  
 Industrial Polishing of Metals (*News*), 184, May  
 Introduction to Servo-Mechanisms, A. Porter, 66, Feb.  
 Limits of Radio Interference, BSS00, 456, Nov.  
 Magnetic Recording, S. J. Begun (*Review*), 403, Oct.; (*Correction*), 463, Nov.  
 Microwave Electronics, John C. Slater, 66, Feb.  
 Newnes Short Wave Manual, Edited by F. J. Camm, 66, Feb.  
 Op-Aid, Amalgamated Short-Wave Press, 60, Feb.  
 Photons and Electrons, K. H. Spring, 66, Feb.  
 Pianos, Pianists and Sonics, G. A. Briggs, 331, Aug.; (*News*), 463, Nov.  
 Post Office Report 1950, 255, July  
 Questions and Answers on Radio and Television, E. Molloy, 66, Feb.  
 R.S.G.B. Call Book (*News*), 374, Sept.  
 Radiolocation, M.I.M.C. Co., 285, July  
 Radio Circuits, W. E. Miller, 238, June  
 — for Merchant Ships, H.M.S.O. (*News*), 412, Oct.

Radio Installations, W. E. Pannett (*Review*), 403, Oct.  
 — Research Board Reports (1933-48), 18, Jan.; (1949), 295, July  
 — Valve Data (*News*), 225, June; 335, Aug.  
 Record Player, Constructional Booklet, Erwin Scharf, 456, Nov.  
 Semi-Conductors, D. A. Wright, 66, Feb.  
 Television Explained, W. E. Miller, 331, Aug.  
 Testing of Hearing Aids, D. B. Fry and P. Denes (*Review*), 360, Sept.  
 Time Bases (2nd Edn.), O. S. Puckle (*Review*), 172, May  
 Trader Year Book (*News*), 268, July  
 Traité de Radioguidage, S. Ostrovidow, 66, Feb.  
 Valve and Circuit Noise, Radio Research Special Report No. 20, 129, Apr.  
 Williamson Amplifier (*News*), 225, June.  
 World Radio Handbook for Listeners 1950/51, O. Lund Johansen, 60, Feb.

**ILLUSTRATIONS**

Airport Control Desks, Aeradio, 503, Dec.  
 Amateur Radio Station, Land Travel Exhibition, 225, June  
 — Television Camera, 319, Aug.  
 — Transatlantic Station Memorial, 100, Mar.  
 B.B.C. Television Map, S2, Feb.  
 Berlin RIAS Station Tape and Disc Recorder, 54, Feb.  
 Canadian Broadcasting Corp. Recording Room, 374, Sept.  
 Daventry Third Programme Transmitter Mast, 182, May  
 — Transmitter Valveholders, 137, Apr.  
 Deflection-Coil Testing, Du Mont Laboratories, 464, Nov.  
 Earls Court Exhibition (Control Room, 414, Oct.  
 Eekersley, T. L., 101, Mar.; 225, June  
 Ediswan 8-channel Electro-Encephalograph, 340, Sept.  
 English Electric 16-in Steel C.R. Tube, 16, Jan.  
 Espley, Dr. D. C., 373, Sept.  
 Fazalbhoy, Y. A., 184, May  
 Holme Moss Aerial, 412, Oct.  
 — Standby Transmitter, 372, Sept.  
 Holmes, R. G. D., 139, Apr.  
 Hunt, Harold, 183, May  
 Largest and Smallest Cathode-Ray Tubes at Earls Court, 436, Oct.  
 Macnamara, T. C., 17, Jan.  
 Manual Volume Expansion, 408, Oct.  
 Maskell, W. A. C., 269, July  
 Mobile Television Station for C.B.C., 501, Dec.  
 Mountbatten, Earl, 314, Aug.  
 Northern Television Map, 15, Jan.  
 Phillips, L. H. J., 102, Mar.  
 Poldhu, Early Marconi Apparatus, 486, Dec.  
 R.C.A. One-Man Television Transmitter, 313, Aug.  
 Radar Mosaic, Decca, 463, Nov.  
 Radio Relay Tower in U.S., 55, Feb.  
 Radley, Dr. W. G., 413, Oct.  
 Reading, Col. J., 413, Oct.  
 Ridgeway, J. W., 102, Mar.  
 Robertson, N. C., 503, Dec.  
 Simpson, T. A., 54, Feb.  
 Smale, J. A., 373, Sept.  
 Sobell Television Receiver Check Panel, 315, Aug.  
 South Bank Sound System, 224, June  
 Soviet Magnetophone, 183, May  
 Spagnoletti, P. H., 139, Apr.  
 Sugden, G. E., 314, Aug.  
 Taylor, W. F., 182, May  
 Television Microscope, 138, Apr.  
 V.H.F. Direction Finder, Marconi, 502, Dec.  
 Wilkinson, Bruce, 55, Feb.

**AUTHORS**

AMOS, S. W., and Johnstone, G. G., 415, Oct.; 452, Nov.  
 Attew, J. E., 517, Dec.  
 BAINBRIDGE-BELL, L., 115, Mar.  
 Bennington, T. W., 26, Jan.; 56, Feb.; 69, 109, Mar.; 160, Apr.; 205, May; 247, June; 288, July; 320, Aug.; 375, Sept.; 418, Oct.; 450, Nov.; 490, Dec.  
 Berth-Jones, F. W., 233, June  
 Bettridge, B. R., 338, Sept.  
 Bolt, F. D., 15, Jan.  
 "CATHODE RAY," 22, Jan.; 61, Feb.; 95, Mar.; 152, Apr.; 193, May; 239, June; 271, July; 325, Aug.; 351, Sept.; 419, Oct.; 469, Nov.; 494, Dec.  
 Cazaly, W. H., 376, Sept.  
 Clarke, Basil R., 135, Apr.; 329, Aug.  
 Cocking, W. T., 171, May; 302, Aug.; 347, Sept.; 425, Oct.; 444, Nov.; 513, Dec.  
 Connelly, F. C., 2, Jan.  
 DAVEY, F. G. G., 31, Jan.  
 Davidson, I. B., 50, Feb.  
 Dent, H. B., 67, Feb.  
 "Diallist," 42, Jan.; 77, Feb.; 124, Mar.; 164, Apr.; 208, May; 249, June; 298, July; 334, Aug.; 380, Sept.; 436, Oct.; 476, Nov.; 520, Dec.  
 Dickinson, C. J., 70, Feb.  
 Dunmer, G. W. A., 510, Dec.  
 Duncan, P. E., 65, Feb.  
 Dutton, G. F., 227, June  
 EAGLESFIELD, C. C., 505, Dec.  
 Exley, K. A., 132, Apr.  
 FINLAY, J. C., 108, Mar.  
 "Free Grid," 38, Jan.; 78, Feb.; 120, Mar.; 166, Apr.; 208, May; 250, June; 300, July; 336, Aug.; 382, Sept.; 428, Oct.; 478, Nov.; 522, Dec.  
 GILLAM, C., 210, June; 279, July  
 HALLOWS, Ralph W., 197, May; 236, June; 434, Oct.  
 Hawker, J. P., 465, Nov.  
 JOHNSTONE, G. G., and Amos, S. W., 415, Oct.; 452, Nov.  
 Jupe, J. H., with Loveiock, R. T., 57, Feb.  
 Jupe, J. H., with Neuberger, S. R., 245, June  
 KELLY, S., 215, June; 256, July  
 Kinross, R. I., 126, Apr.  
 LOVELOCK, R. T., and Jupe, J. H., 57, Feb.  
 Lowden, R. W., 283, July  
 MARTIN, A. V. J., 459, Nov.  
 Mayson, B., 404, Oct.  
 Moir, J., 84, Mar.; 262, July  
 Mortley, W. S., 399, Oct.  
 NEUBERGER, S. R., and Jupe, J. H., 245, June  
 PAGE, H., 168, May  
 Parkin, P. H., and Scholes, W. E., 44, Feb.  
 Pipe, D. W., 117, Mar.  
 "Pronto," 73, Feb.  
 RODDAM, Thomas, 29, Jan.; 112, Mar.; 221, June; 316, Aug.; 341, Sept.  
 SCHOLES, W. E., with Parkin, P. H., 44, Feb.  
 Scroggie, M. G., 175, May; 396, Oct.  
 Shears, P. A., 355, Sept.  
 Spencer, J. G., 440, Nov.; 487, Dec.  
 Spratt, H. G. M., 88, Mar.; 149, Apr.  
 Styles, H. E., 306, Aug.  
 TAYLOR, P. L., 7, Jan.; 161, Apr.  
 Tusting, W., 310, Aug.; 507, Dec.  
 VAUGHAN, J.F.O., 480, Dec.  
 WALKER, A. H. B., 27, Jan.  
 Wells, O. C., 35, Jan.  
 Woodville, G., 148, Apr.  
 YOUNG, Ronald G., 451, Nov.



# Wireless World

JANUARY 1951

VOL. LVII. No. 1.

## ***Fire and Shock***

**I**T would be unwarrantably alarmist—indeed, quite untrue—to suggest that domestic broadcast and television receivers are serious sources of electrical dangers to their users. On the contrary, by their nature and method of use they are probably responsible for fewer fires and cases of shock than any one of half a dozen household electrical appliances. However, it seems well established that fires ascribed to receivers are on the increase. Though the actual number may be trivial, the curve is rising very steeply. Further, the fire risk due to television is disproportionately large as compared with sound-only sets. One of the reasons for the increase, no doubt, is that the average age of sound receivers is increasing; many are over 10 years old. Television troubles may be partly due to the newness of the design technique.

Electrical engineers in the old-established branches are apt to express disapproval at the absence from radio receivers of the protective measures to which they are accustomed, but, when pressed to go into details and to make constructive suggestions, they are generally forced to concede that methods applicable to other appliances would be either impracticable or ineffective. Perhaps, though, there is a grain of truth behind these strictures; some designers in the rapidly growing radio art, concerned mainly with fundamental developments, may feel inclined to take safety precautions in their stride. Others may still be influenced by the practices of an earlier epoch when radio equipment was designed for operation entirely by those trained in its use, and not by the ordinary householder. There was a day when transmitter h.t. bus-bars were unguarded and when the user depended entirely on his nose for warning that something should be done to check an incipient fire.

Be that as it may, all designers are now well aware of the problems involved, and it is all to the good that they should be freely discussed, as there is still divergence of opinion as to which precautions are most effective. An article printed on another page describes the general nature of fire and shock risks, and also deals with some of the more widely accepted protective devices and methods of attack.

Of these devices, the so-called temperature fuse is the most interesting. The conventional electrical fuse, depending for its protective action on the passage through it of an excessively heavy current, has a distinctly limited application in radio equipment. The temperature fuse, which can be arranged to interrupt an electrical circuit when the temperature of a component to which it is attached (or of the surrounding air) reaches a dangerously high level, overcomes many of the disabilities of the older method. Some of these disabilities can, however, be overcome by using time-delay fuses which are not "blown" by surges. In its cheapest and simplest form the temperature fuse consists of a short conductor of low-melting-point alloy, but a number of rather more complicated arrangements are possible.

Devices of this kind have been used for some time and are standard articles of commerce. Some temperature fuses can be reset by the user, but we imagine the kind favoured for domestic radio sets will require attention from the service technician, who will at the same time investigate the cause of the rise in temperature that caused the fuse to "break."

Fortunately, the extra precautions that meet with favour are not unduly costly, nor are they likely appreciably to increase the susceptibility of a receiver to develop faults in normal service.

Information as to the precise causes of fire (and to a lesser extent shock) brought about by domestic receivers is hard to come by. We suspect in many cases the associated section of the domestic wiring is as much to blame as the radio equipment proper. For instance, judging by correspondence and our own observation, it is all too common to find electrical outlet sockets switched in the "dead" lead. However, that is no reason why radio sets should not be as far beyond suspicion as all reasonable precautions can make them. None of us want a state of affairs to arise where the reporters of the lay Press, instead of ascribing the causes of a fire to the classical "fusing of an electric wire," decide there is more news value and modernity in fires caused by "a faulty television receiver."

# Safety Precautions

## *Reducing Fire and Shock Risks in Domestic Receivers*

By F. C. CONNELLY, Ph.D., A.M.I.E.E. (Murphy Radio)

**D**URING the past two or three years there has been considerable interest, both in this country and internationally, in the safety aspects of domestic electrical equipment. Radio apparatus has naturally been included in the discussions and a considerable amount of work on the problem has been carried out in the industry. It should not be assumed from this that radio receivers have been found to be a serious source of danger; they are, in their normal state, probably much less likely to cause accidents than many other domestic appliances. Nevertheless there have from time to time been fatalities from shock or fire, nearly always due to mishandling by the user or to deterioration of components within the receiver. Because of this several organizations representing the various interests connected with radio and television have been attempting to reduce these already small risks to even smaller dimensions.

In this country the British Radio Equipment Manufacturers Association has taken an active part in investigating possible causes of trouble and the British Standards Institution is in the process of redrafting BS415 to accord with current developments. In some countries, notably the Scandinavian ones, compliance with the national safety specification has to be certified by the official testing laboratory before a receiver or other domestic appliance can be marketed. Naturally there has been a tendency

A typical temperature fuse fitted to a mains transformer. The primary circuit is completed through the replaceable stirrup joining the two contact strips. The inner strip of copper is inserted between the windings when the coil is wound and if the temperature becomes excessive the stirrup, which is joined together by low-melting-point alloy, flies apart under the action of the outer spring strip.

*Courtesy Mullard Electronic Products*

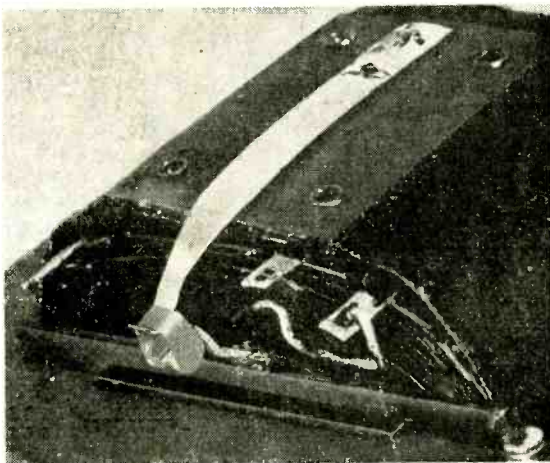

for each country to decide upon slightly different requirements and this has hampered international trading; in consequence several meetings of the radio-communication committee of the International Electrotechnical Commission have been devoted to discussion on the points of divergence and at the recent I.E.C. meeting in Paris a very large measure of agreement was reached. Representatives of both the testing institutes and the manufacturers are present at these meetings so that a balanced solution can be found.

In Britain the electrical supply organizations have favoured the earthing of exposed metal parts on electrical appliances of all kinds as an important measure of safety. To meet the earthing requirements portable apparatus has usually to be installed with three-core cables and three-pin plugs, although certain exceptions are permissible. From safety considerations it would appear to be desirable that radio receivers, too, should be installed with three-core leads to ensure the efficient earthing of exposed metal parts, including (as regards mains frequencies) the aerial and earth leads, pickup, loudspeaker, etc. Unfortunately the requirements of safety and reduction of man-made interference are likely to be in conflict here and some alternative to the earthing technique would be desirable. On the continent, earthing of domestic appliances is not the usual practice and little reliance is placed on it. As probably the majority of users of radio sets even in this country have no facilities for connecting their apparatus to an earth continuity conductor in their house, earthing can at best only be regarded as an additional precaution rather than a primary method of ensuring safety.

**Possible Dangers.**—The principal electrical dangers which can arise in a receiver are shock from touching some live part of the apparatus and fire from overheating. The reason why so much thought has been given to these hazards in receivers is not the frequency of their occurrence but the fact that the circuits of these devices are much more complicated than those of most other domestic apparatus. Straightforward fuse protection, for example, is often impracticable owing to the large current surge which occurs when a set is first switched on. Again, the rise in input current due to a fault in one part of the circuit may be too small to ensure operation of a fuse in the mains circuit and yet the consequent overheating in that part may be sufficient to start a fire. Fires in radio equipment, particularly television, are actually a greater cause of anxiety than shock risks and much of the recent work has been concerned with means of minimising the effects of overheating following the breakdown of insulation.

The most important development in the pursuit of an improved standard of safety is the recognition that certain components or methods of construction may become faulty during the life of a set in such a manner



as to endanger persons using it. According to this principle a receiver cannot be considered to be completely safe unless it remains free from danger even when these components have failed. The faults which are expected to occur are mostly breakdowns of insulation such as that of an electrolytic capacitor, or between the electrodes of a valve; when a short-circuit occurs at any or all of these doubtful points, the equipment should either remain safe or protective devices must come into operation to disconnect it from the supply mains. It is convenient in what follows to describe an apparatus as operating under "normal conditions" when it is in the state in which it was designed to be used and under "fault conditions" when artificial short-circuits (or in some cases open-circuits) have been applied to any or all of the points specified as being of doubtful insulation (or liable to disconnection).

**"Normal Condition."**—Taking first of all "normal conditions," so long as a receiver remains in the state in which the designer intended it to be the risk of an accident is very small. Naturally no designer would knowingly turn out a model in which he thought there was a risk of contact with live parts or in which excessive temperatures were reached. It is, however, somewhat a matter of opinion as to what is, for example, the highest permissible operating temperature for a particular kind of material and also exactly what degree of protection is required against contact with live parts—it would no doubt be possible to get a shock from almost any mains-operated device if one were sufficiently ingenious in poking knitting needles and such things into it! To arrive at a uniform standard of safety in respect of contact with live parts it is necessary to adopt standardized contact devices which are applied to different parts of an apparatus to see whether they can be made to touch dangerous points. For most situations an artificial "standard finger" is used (Fig. 1); this is 12 mm diameter and 80 mm long, tapered and flattened at the end to represent the general shape of a human finger and provided with two joints which can be set to any angle assumed by a real finger. In addition to this general test, certain parts such as control shafts on sets with live chassis are checked for accessibility with special test devices, such as a 2 mm flexible cord.

On the fire risk side the temperature rises of the working parts of reputable receivers under normal operating conditions are nearly always well below the danger point, but, again for uniformity, maximum working temperatures for different classes of materials are laid down in test specifications as well as the highest allowable temperatures for external parts such as control knobs, cabinet, etc.

**"Fault Conditions."**—As already indicated, compliance with the requirements for "normal operation" involves few departures from usual practice and most current production receivers satisfy these conditions. It is in providing the protective arrangements to ensure safety from shock and fire under fault conditions (when any part which cannot be reasonably considered completely reliable has broken down) that most of the ingenuity is required.

The parts which are generally considered to be liable to breakdown, besides the electrolytic capacitors and valve electrode clearances already mentioned, include rectifiers of any type, variable and air-dielectric capacitors, varnish or enamel layers (except as inter-turn insulation in coils) and any creepage or clearance distances in air or in vacuo

less than certain figures laid down. To prevent danger when a failure occurs in one of these parts the designer has several courses open to him: he can avoid the use of the components in question, arrange that no danger is present even if they are short-circuited, or, thirdly, employ fuses or other overload devices to disconnect the circuits. The first method—refraining from using the parts named—is hardly practicable in all cases. It is sometimes not difficult, as in the case of an output transformer subjected to a large current because the output valve electrodes are short-circuited, so to proportion a part that it can take the overload without reaching dangerous temperatures or failing in primary-secondary insulation, but usually the designer has to apply the third method of finding a way of providing protection by some form of cut-out.

It must not be forgotten that safety from shock as well as fire risks is involved under fault conditions. For example, the clearance distances between any live parts and any accessible metal parts must never be less than the specified distances, nor must paint or textile material be used as the sole insulation for live parts; these would have to be short-circuited during the fault test. Aerial, earth, loudspeaker and pickup sockets must, in principle, be considered as accessible parts, even if the sockets are so recessed as to prevent contact with the standard test finger, because the user is liable to connect bare, or lightly insulated, leads to these points when installing his receiver. In consequence of this, the insulation between high-voltage points and these circuits must not depend on air-dielectric or variable condensers nor must it be possible for a breakdown between any pair of valve electrodes to put an unsafe voltage on these sockets. The case of an output transformer already mentioned is a more complicated one, involving, as it does, both fire and shock considerations. Generally speaking, however, fire is the most likely contingency which has to be met under fault conditions and some typical problems and their solutions will be examined.

**"Isolated Apparatus."**—Take first of all an A.C. receiver supplied from the mains through a double-

Fig. 1. A "standard finger" for checking whether live parts are sufficiently guarded against contact. This device has been standardized internationally.

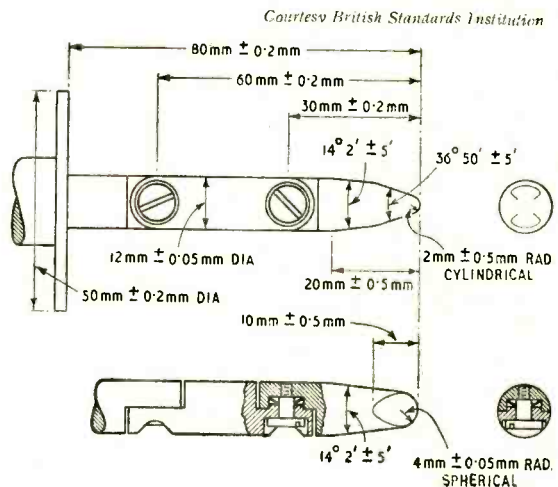

wound transformer—an "isolated" receiver as it is described in "safety" terminology (see Fig 2). Short-circuits in the heater or pilot lamp circuits or in the h.t. rectifier, reservoir capacitor or perhaps even in the smoothing capacitors are bound to increase the current through the mains transformer primary to an appreciable extent and it might at first sight have been considered satisfactory to deal with these faults by inserting a fuse in the primary circuit. Unfortunately, this is not such a straightforward method as might have been expected, because at the moment of switching on a very large current surge may occur. The magnitude of the peak current reached depends on the instant in the applied voltage cycle at which the switch made contact, completion of the circuit near a voltage zero resulting in a large current surge and at a voltage maximum little or no excess current. Special fuses having a long time-delay can sometimes be used satisfactorily in these conditions, but a more sensitive method of discriminating between faults and switching surges is to fit a cut-out which depends for its operation on the temperature of the transformer windings themselves. The transformer itself is, of course, rendered completely safe by this means because it can never attain a dangerous temperature as the current is cut off before this happens. One way of constructing the thermal cut-out uses a low-melting-point alloy to bridge a pair of sprung contacts in the primary circuit whilst another incorporates a bi-metallic strip. The latter method can be arranged to permit resetting by means of a button—this may or may not be advantageous.

There seems to be little doubt that the heat-fuse method is the most satisfactory way of dealing with potential short-circuits in both l.t. and in the good-regulation sections of the h.t. circuits in "isolated" receivers. The low-current circuits supplying the screens and anodes of early stage valves, however, remain unprotected, and unless other precautions are taken there is a danger of fire due to overheating of the feed resistances if the electrodes concerned become connected to, say, the cathode or suppressor grid. The resistance involved can, depending on its value, either be made of such a rating as to be able to withstand the full voltage of the h.t. supply without danger of fire, or it can be of a type (such as "wire wound") that it burns out without risk of setting fire to surrounding components or wiring. If this latter alternative is adopted care must be taken in the location of the resistor; e.g., it may be mounted on fireproof supports above the chassis. This is a convenient way of dealing with smoothing resistors used in the simpler types of receiver instead of smoothing chokes. They are usually of the order of 2,000 ohms and cannot therefore be made capable of withstanding the full h.t. without considerable expense. Smoothing chokes, if used, are likely to have a good margin of safety from the temperature rise point of view, as they are generally designed to have a low voltage drop. It may therefore be possible to short-circuit a smoothing capacitor on the output end of such a choke without causing the temperature rise to exceed a safe figure; if not, an h.t. line fuse may be required. Connected in series with an inductive element there is little likelihood of spurious operation due to current surges when charging up capacitors as the set warms up. Summing up, the greater part of the "isolated" type of radio receiver can be protected by the provision of a

thermal device built into the mains transformer, whilst fire risks in the remainder can usually be dealt with by suitable positioning of feed resistors.

**"Non-Isolated" Sets.**—The "non-isolated" (or a.c./d.c.) type has problems of its own and requires different methods of treatment. Even to meet safety requirements under normal conditions of operation current practice may have to be modified in some respects, notably in the amount of attention which is paid to the isolation of aerial, earth and pick-up sockets from the mains. It has now been established that well over 90 per cent of persons can feel a current of 0.5 mA (r.m.s.) at mains frequencies and it is obviously desirable that it should not be possible to draw currents exceeding this figure from any accessible point on an equipment. In that connection the sockets for aerial, earth, pick-up and loudspeaker should be regarded as accessible even if the terminal points themselves are recessed or otherwise protected since the user may connect bare or lightly insulated wires to them. Limitation of the permissible current to 0.5 mA, however, may involve serious restrictions in the design of the signal- and audio-frequency portions of a receiver circuit: as numerous tests have shown that currents up to at least 5 mA can be passed between the hands or hand and foot without producing cramping of the muscles and consequent inability to let go, currents up to about 2 mA are probably not dangerous although quite unpleasant. This does not apply to the aerial terminal, as window cleaners, painters and others may come in contact with the aerial wires when perched precariously on ladders, etc. Under these conditions, of course, only a very slight shock may cause a fall with serious consequences. As it is usually possible to restrict the mains frequency current through the aerial to figures well below 0.5 mA without prejudicing the R.F. performance, a blocking capacitor of approximately 0.001  $\mu$ F should be inserted in series with the aerial terminal, or other similar measures adopted (see Fig. 3).

Non-isolated receivers are usually dependent on capacitors for the isolation of accessible parts from the mains so that great care has to be exercised in the choice of suitable capacitors and in the provision of reliable mounting and wiring to ensure that the capacitor is not short-circuited externally. An important development in recent work has been the recognition that a capacitor having an extremely long life when subjected to a particular d.c. voltage may fail at a very early stage when used on a.c. having a peak voltage no higher than this d.c. value. Paper-dielectric capacitors having solid impregnants (e.g., waxes) have been found to suffer rapid deterioration under a.c. stresses whereas oil impregnation gives excellent results. Mica, once specified as the height of perfection in dielectrics, is also liable to breakdown under a.c. operation at voltages much lower than would have been expected from its performance on d.c. The trouble is due to the formation of minute voids within the dielectric. The electrical stress at these points is high due to their lower s.i.c. and ionization occurs with rapid deterioration of the material. Fluid or semi-fluid impregnants are naturally much less likely to allow voids to form. Because of these possibilities of failure it is obviously essential for the designer to specify isolating capacitors of a type which have been proved to have an indefinitely long life under a.c. mains voltage conditions.

Live shafts on non-isolated equipment are a poten-



tial danger of shock. Even if the knobs are really securely fixed (and this is not always the case) there may be sufficient space between the back of the knob and the cabinet to allow metal objects to fall through and touch the shaft. A tube of insulating material or an extension of the knob within the cabinet is advisable to prevent trouble here.

Another feature of present-day non-isolated sets which may require attention in order to comply with the standards which are now laid down in several European countries is the aerial circuit switching arrangements. Creepage distances between adjacent contacts or between certain contacts and the frame of many of the wafer-type switches in general use are decidedly less than the requirements demanded for the insulation of parts at mains potential. As the frame of the switch is usually connected directly to the chassis by the mounting bush and in addition some of the contacts may also be connected to chassis (which is in turn connected to one pole of the mains) arrangements will have to be made to ensure either that the aerial coupling winding contacts are adequately separated from the danger points or that the coil circuit is itself isolated from the aerial and earth sockets.

When we turn to the safeguarding of non-isolated models against fire under "fault conditions" we come up immediately against the fact that there may be no central power source corresponding to the transformer in an isolated set and consequently we cannot base our protection on a thermal release located between the windings. Receivers employing auto-transformers are, of course, classed as non-isolated and in their case the thermal release is applicable but true a.c./d.c. apparatus has to be dealt with by current fuses. The occurrence of heavy surges at the moment of switching on a set (as in the heater circuit when

starting from cold or in the h.t. circuit when switching on again soon after switching off whilst an indirectly heated valve rectifier is still hot) will often present problems. It is seldom possible to secure full protection with one fuse; the heater and h.t. circuits have to be treated separately. A long time-lag fuse is necessary in the heater circuit and this may be used as a main input fuse as it can often be chosen to deal with short-circuits in the rectifier or reservoir capacitor. Breakdowns in the smoothing capacitors are, however, unlikely to cause a sufficient increase in the current to cause the main fuse to blow, owing to the limiting effect of the smoothing chokes or resistors. A sub-fuse should therefore be used which carries only the h.t. current; as this can be connected in series with the choke or resistor, surges are, by the nature of the smoothing circuit, avoided and plain fuses are usually satisfactory.

As in isolated receivers, the feed resistors of anode and screen circuits are best dealt with by choosing wattage ratings which will withstand the full h.t. without risk of catching fire, or, alternatively, positioning them so that there is no danger of adjacent components such as waxed coils or capacitors becoming overheated.

**Television.**—Although the foregoing paragraphs refer primarily to sound receivers, the principles are directly applicable to television sets. The guarding of live parts to prevent shock, for example, follows the same technique as for radio equipment. At first sight it might have been expected that more stringent precautions would have been required owing to the existence within the receiver of voltages up to 12 kV or more. When it was the standard practice to obtain e.h.t. from a winding on the 50-c/s transformer through a rectifier these fears would have been justified, not only because of the relatively high current

(Below) Fig. 2. The power supply and audio stages of an "isolated" receiver showing some of the points which have to be short-circuited during a fault test. No danger should result if points having corresponding letters; e.g. BB, are connected together. Short-circuiting AA, BB or CC would result in the operation of the temperature fuse. Joining DD or FF would cause the smoothing resistor to over-heat, but if suitably located no harm would result. It is quite practicable to choose the wattage of the anode coupling resistor so that joining GG does no harm. Short-circuiting HH has little effect on the current distribution.

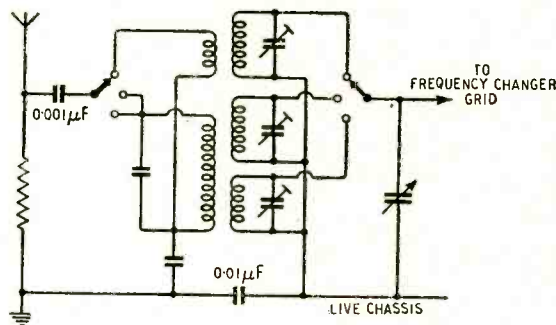
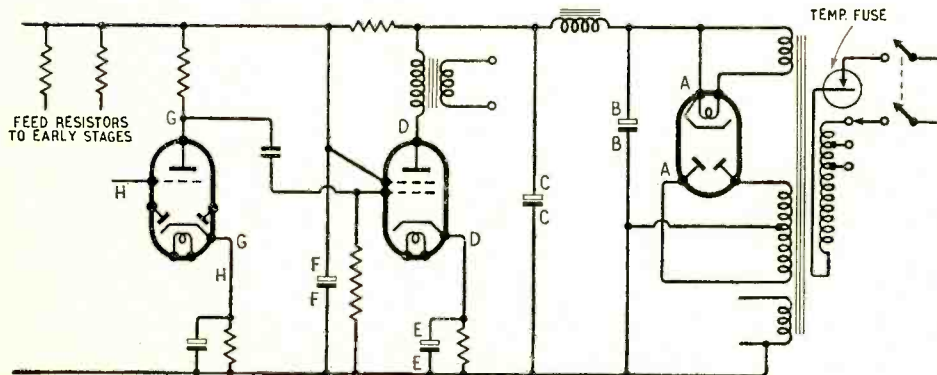

Fig. 3. The aerial circuit of a non-isolated receiver. During a fault test many wafer-type switches would have to be short-circuited because their clearances are less than those specified. This involves blocking capacitances in aerial and earth connections. A leak should be provided from aerial to earth to drain away static charges which may accumulate.

which could be drawn from these supplies but also on account of the large smoothing capacitors which could remain charged after the set had been switched off unless discharge resistors were fitted. Now, however, fly-back systems of obtaining the accelerating voltage for the c.r.t. are very frequently used and neither of these considerations applies; it is very unlikely that a dangerous shock could be obtained by touching the e.h.t. supply when a set is working.

External connections to a television receiver are usually confined to the aerial feeder so that isolation difficulties, even on a "live-chassis" set are not troublesome. The feeder cable itself is usually covered by a layer of PVC or similar material, so giving an additional measure of protection should the isolation fail within the receiver.

Fire risks, on the other hand, require more attention—not only are there about three times as many stages to give trouble, but also the technique is less well established and breakdowns of insulation are consequently more likely to occur. The line scan circuits, for instance, often develop several kilovolts, apart from any step-up winding on the transformer for the specific purpose of obtaining e.h.t. supplies. The necessity for low values of self-capacitance in the line scan windings restricts the designer to small physical dimensions and increases the difficulties of insulating the coils adequately. The use of better materials and newer methods is overcoming these weaknesses, but there are potentialities for trouble in this part of the receiver.

When a mains transformer is used the temperature

fuse can be used to deal with many of the possible breakdowns in electrolytic capacitors and rectifiers. The older technique of obtaining e.h.t. from a winding on the transformer was apt to present difficulties in arranging the temperature fuse because a winding of this kind had necessarily to be well insulated electrically. As good electrical insulators are practically always good thermal insulators it was difficult to avoid overheating of the e.h.t. coil before the heat was conducted to the temperature fuse. The fly-back technique has eased matters here as well as on the shock side. H.T. line fuses are commonly fitted to deal with failures of components in the circuits fed from subsidiary smoothing filters where the effect on the main h.t. current would be small. As in radio receivers, careful placing of feed resistors liable to overheat if short-circuits develop in valves or tuned windings is essential to avoid the rapid spread of flames. The use of PVC-covered connecting wire is another important contribution, as this material does not continue to burn of its own accord, whereas rubber coverings form easy channels whereby fire may spread from one part of a set to another.

**Conclusion.**—The recognition that we cannot hope to ensure in an apparatus as complex as a radio or television receiver that no component ensuring freedom from shock or fire risks will ever fail, is bound to lead to an improved standard. Protective devices are being developed in various quarters to implement the proposals that every set should be able to deal safely with failures of insulation in components such as electrolytic capacitors, valves and switches.

## NERVE COMMUNICATIONS

THERE are so many striking resemblances nowadays between electronic devices and the human body that it has become fashionable for medical men and engineers to look for analogies in each other's work as a means to the better understanding of their own. Neurologists in particular are tending to regard the nervous system, which conveys information about the body, as a vast communications network, and are hoping that the knowledge of communications engineers will prove valuable in studying the complex "circuitry" of this network on a more scientific basis.

This method of approach was perhaps influenced by the fact that information is actually conveyed along the nerve fibres of the body by electrical impulses. Furthermore, these impulses are transmitted by sensory organs, such as the eyes and ears, and received by motor organs, such as muscles and glands, all of which have obvious electrical counterparts. The complex groups of nerve cells or ganglia existing in the spinal cord and brain can similarly be compared with telephone exchanges or the "brains" of electronic control devices.

Analogies of this sort, however, cannot be taken too far, as there are some important differences to be considered. For instance, the impulses are not conducted along the nerves as they would be along wires, but move comparatively slowly (about 80-100 metres per sec) as a kind of "travelling breakdown" of the polarizing voltage that exists between the inner

core and outer sheath of a nerve fibre. Furthermore, since the process of breakdown and restoration takes time to complete, there is a limit to the rate at which the impulses can be transmitted and the nerves do, in fact, "cut-off" like a filter at a repetition rate of about 500 per second. This latter point was raised at an informal discussion on "The Nervous System as a Communication Network," held at the I.E.E. on 20th November, 1950, when one of the speakers asked how was it possible, in these circumstances, for us to hear frequencies up to about 15 kc/s. In reply, the lecturer (Dr. J. A. V. Bates) said that the frequency discrimination of hearing was not done in the nervous system at all but in the inner ear. This had a resonant structure which responded at different points corresponding to different frequencies, and since the endings of the auditory nerve fibres were spatially distributed over this structure they could identify the frequencies by their position and convey the result to the brain. The actual repetition rate of the impulses along a nerve was merely a measure of the intensity of the stimulus, in this case sound.

Discrimination by position occurs in a similar way in the other sense organs, the spatial distribution of nerve fibres being repeated at the far end of the "line" by a corresponding distribution on the brain itself. To carry the information in this fashion, a large number of individual channels are required, and in the optic nerve of the human eye, for example, there are something like a million separate fibres.



# Ribbon Loudspeaker

*Principles of Design and Constructional Details of a High-frequency Unit Making Use of a Magnetron Field Magnet*

By P. L. TAYLOR, M.A.

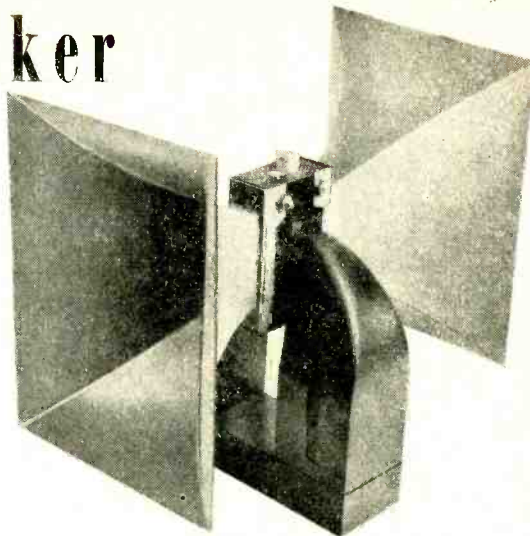

THE unit to be described has given excellent results and is comparatively simple to make. The basis of the design is a Government-surplus magnetron magnet; but these vary in dimensions, gap widths and flux densities, and to enable the home constructor to modify the design to suit any particular magnet, some elementary theory is given which will serve as a guide to the orders of magnitude of the quantities involved and to the effect of changes in the design on the final results.

It is well known<sup>1</sup> that when a sound is propagated through air the air particles, normally at rest, are set in vibration longitudinally, i.e., along the direction of propagation. This movement of the particles gives rise to the variation of air pressure, above and below atmospheric, that constitutes the sound wave. At a particular point in the medium, whenever the particles are moving forward (in the same direction as the sound) the pressure is above atmospheric, and when they move backwards the pressure is below atmospheric. It can be shown that, if  $p$  is the pressure excess and  $v$  the *particle* velocity (not the velocity of the sound wave) the ratio  $p/v$  is a constant determined by the characteristics of the medium. This constant is known as the unit area

impedance of the medium, and denoted by  $Z_u$ . We have therefore

$$\frac{p}{v} = Z_u \quad \dots \quad (1)$$

For plane waves in air, if  $p$  and  $v$  are measured in c.g.s. units (dynes/cm<sup>2</sup>, and cm/sec respectively)  $Z_u = 41.2$  c.g.s. units. This is only true if the waves are plane; for diverging and converging waves the relation between  $p$  and  $v$  is more complicated, but need not be considered here.

Consider a ribbon carrying a current in a magnetic field (Fig. 1). It will experience a force tending to move it in a direction at right-angles both to the direction of the field and the direction of the current. This movement will be communicated to the air, and if the current is alternating the movement will also be alternating, giving rise to the radiation of a sound wave. But at high frequencies the inertia of the ribbon will prevent it moving as much as it should, and the radiated power will fall off. Obviously, for good high-frequency response as light a ribbon as possible is called for; but the matter is not quite as simple as that.

Using the symbols given in Table I, we can write:

$$F_1 = BaI \text{ dynes} \quad \dots \quad (2)$$

$$F_2 = 2pab \text{ dynes} \quad \dots \quad (3)$$

(the factor 2 allows for the two faces of the ribbon)

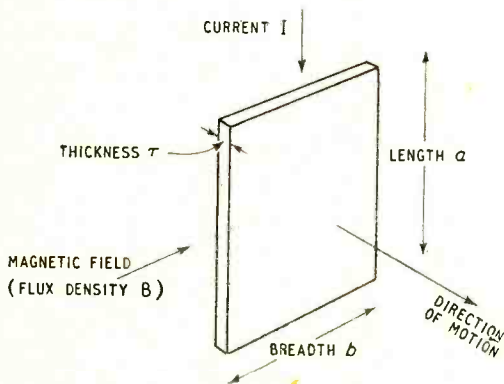

Fig. 1. Relevant dimensions of ribbon in a magnetic field.

TABLE I

Quantity	Symbol	Unit
Magnetic flux density	B	gauss
Length of ribbon	a	cm
Breadth of ribbon	b	cm
Thickness of ribbon	τ	cm
Density of ribbon material	ρ	gm/cm <sup>3</sup>
Mass of ribbon	M = abτρ	gm
Resistivity of ribbon material	q	ohm/cm
Air pressure excess	p	dyne/cm <sup>2</sup>
Air particle velocity	v	cm/sec
Displacement of ribbon from rest position	x	cm
Current through ribbon	I	c.m.u.
Electromagnetic force on ribbon	F <sub>1</sub> = BaI	dyne
Acoustic force on ribbon	F <sub>2</sub> = 2pab	dyne

<sup>1</sup> See, for example, "Acoustics," by Alexander Wood (Blakie and Sons)

when there is a pressure excess on one side of the ribbon there will be a pressure deficit on the other, so that the force on the ribbon will be twice that on one face.) Making the assumptions that the air particle velocity is equal to the ribbon velocity, and that the radiated waves are plane, equation (1) holds and substituting this in equation (3) gives

$$F_2 = 2abZ_u v \\ = 2abZ_u \frac{dx}{dt} \quad \dots \quad (3a)$$

The resultant of  $F_1$  and  $F_2$  will cause acceleration of the ribbon, and, assuming that it moves as a whole and has negligible stiffness at its supports, we can write:

$$F_1 - F_2 = M \frac{d^2x}{dt^2} \quad \dots \quad (4)$$

Substituting equations (2) and (3a) and the mass of the ribbon as given in Table I we get:

$$IaB - 2abZ_u \frac{dx}{dt} = \rho ab \tau \frac{d^2x}{dt^2} \quad \dots \quad (5)$$

But the voltage  $V$  across the ribbon is given by

$$V = aB \frac{dx}{dt}$$

and therefore 
$$\left. \begin{aligned} \frac{dx}{dt} &= \frac{V}{Ba} \\ \frac{d^2x}{dt^2} &= \frac{1}{aB} \frac{dV}{dt} \end{aligned} \right\} \dots \quad (6)$$

Substituting equations (6) in (5) gives

$$IaB = 2Z_u ab \frac{V}{aB} + \frac{\rho ab \tau}{aB} \frac{dV}{dt}$$

or 
$$I = \frac{V}{\frac{aB^2}{2Z_u b} + \frac{\rho b \tau}{aB^2}} \frac{dV}{dt} \quad \dots \quad (7)$$

Fortunately it is not necessary to solve this equation, which connects the voltage across the ribbon with the current through it, i.e., represents the electrical impedance between the ends of the ribbon due to the fact that it is moving. This impedance is called the "motional impedance" of the ribbon.

TABLE II

1 ampere	=	0.1 e.m.u.
1 volt	=	$10^8$ e.m.u.
1 ohm	=	$10^9$ e.m.u.
1 farad	=	$10^{-9}$ e.m.u.
1 henry	=	$10^9$ e.m.u.

Fig. 2. (a) Equivalent circuit of motional impedance of ribbon, and (b) with the addition of  $R_1$ , the d.c. resistance.

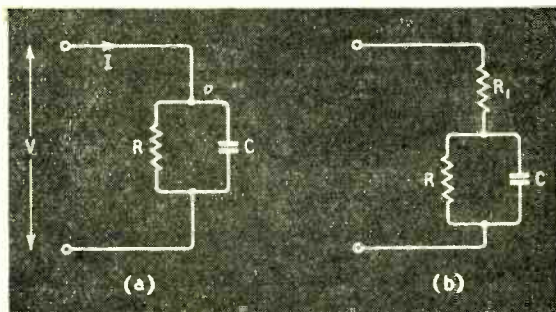

We may find it by comparing equation (7) with the equation of current and voltage in the circuit of Fig. 2(a).

$$I = \frac{V}{R} + C \frac{dV}{dt} \quad \dots \quad (8)$$

Equations (7) and (8) are of exactly the same form, so the motional impedance is evidently a resistance and capacitance in parallel, where

$$R = \frac{aB^2}{2Z_u b} \text{ e.m.u.}$$

$$C = \frac{\rho b \tau}{aB^2} \text{ e.m.u.}$$

These electromagnetic units must be converted to practical units (Table II) and we get:

$$R = \frac{aB^2}{2Z_u b} \times 10^{-9} \text{ ohm} \quad \dots \quad (9)$$

$$C = \frac{\rho b \tau}{aB^2} \times 10^9 \text{ farads} \quad \dots \quad (10)$$

But Fig. 2(a) does not represent fully a practical ribbon; for the voltage  $V$  in equations (7) and (8) is the back e.m.f. produced by the motion of the ribbon which in the practical case is much less than the e.m.f. applied to the ribbon by a generator. The difference is due to the voltage drop in the normal electrical resistance of the ribbon (and strictly speaking also in the inductance of the ribbon and the leads to it: but for the moment we may ignore this). The equivalent circuit of a practical ribbon is therefore Fig. 2(b) where  $R_1$ , the d.c. resistance of the ribbon, is given by

$$R_1 = \frac{\sigma a}{b \tau} \text{ ohms} \quad \dots \quad (11)$$

From this figure we can see that when an alternating voltage is applied part of the energy is absorbed uselessly by  $R_1$  and part is radiated as sound; this radiated energy is represented by that absorbed in the "radiation resistance"  $R$ . As the frequency increases the radiation is decreased by the effect of the mass of the ribbon, represented by the shunting of  $R$  by a capacitance  $C$ .

Two considerations enter into the design of a ribbon loudspeaker: first, the efficiency, i.e., the fraction of the total energy supplied to the ribbon that is actually converted to sound, and second the frequency response.

Fig. 2(b) shows that, at a low frequency where the effect of  $C$  may be neglected, the efficiency  $\eta$  is given by

$$\eta = \frac{R}{R + R_1} \quad \dots \quad (12)$$

and the radiated power will fall by 3db at a frequency at which the voltage across  $R$  falls by 3db. This is determined by the time-constant  $T$  of the circuit which, assuming it to be fed from a low-impedance source, is the product of  $C$  and the parallel combination of  $R$  and  $R_1$ , i.e.,

$$T = C \frac{R R_1}{R + R_1} \quad \dots \quad (13)$$

and the radiated power will fall by 3db at a frequency given by

$$f_{-3db} = \frac{1}{2\pi T} \quad \dots \quad (14)$$



It is difficult to see immediately from the foregoing equations which are the most important variables to be fixed at the outset in attempting a design, as  $T$  and  $\eta$  are obviously closely related, and changing one by altering the design will affect the other. We may therefore introduce the idea of a "figure of merit" given by the fraction  $\eta/T$ , which must be as large as possible since we require  $\eta$  to be large and  $T$  small. From equations (12) and (13),

$$\frac{\eta}{T} = \frac{1}{CR_1} = \frac{B^2}{\rho\sigma}$$

which makes the problem look much simpler, as all the dimensions of the ribbon have disappeared. This equation shows that only two quantities are prerequisites of a good design: the flux-density and the material of which the ribbon is made.  $B$  must be as high as possible, and even a small improvement is worth striving for as the figure of merit is proportional to the square of  $B$ . It is interesting that it is not  $\rho$  and  $\sigma$  separately that are important, but their

product. Table III gives the values of  $\rho\sigma$  for various metals; magnesium seems an obvious choice with aluminium a close second. In practice aluminium is used as it does not tarnish and is readily obtainable in the form of foil.

Having obtained as high a value of  $\eta/T$  as possible, design procedure is then to choose the ribbon thickness so that  $\eta$  is about the same as that of the main loudspeaker with which the unit is to be used; this in turn fixes  $T$  and the frequency response. As an example, the figures in Table IV apply to the aluminium ribbon used in this design. It is interesting also to calculate the results that theoretically could be achieved using the best magnet materials that are at present commercially available, and a thinner aluminium ribbon. Assuming  $B = 15,000$  gauss,  $\eta = 0.2$ , we find that  $f_{-3db} = 20.6$  kc/s and  $\tau = 0.00012$  in.

**Horns.**—The fundamental assumption was made above that the ribbon would be radiating plane waves so that we could equate the ribbon velocity and the acoustic pressure with  $Z_u$  (equation (1)). But

TABLE III

Metal	Density $\rho$ (gm/cm <sup>3</sup> .)	Resistivity $\sigma$ (ohm/cm.)	$\rho\sigma$
Magnesium	1.74	$4.35 \times 10^{-6}$	$7.57 \times 10^{-6}$
Aluminium	2.7	3.21 "	8.67 "
Copper ...	8.93	1.78 "	15.85 "
Silver ...	10.5	1.66 "	17.4 "
Zinc ...	7.1	6.1 "	43.2 "
Gold ...	19.32	2.42 "	46.8 "
Tin ...	7.29	11.3 "	82.5 "

TABLE IV

$B$	12,500 gauss	$R$	$7.6 \times 10^{-3}$ ohm
$a$	1.5 inches	$C$	$3.3 \times 10^{-3}$ farad
$b$	0.375 inch	$\eta$	0.31
$\tau$	0.0003 inch	$T$	$1.7 \times 10^{-5}$ sec
$R_1$	$17 \times 10^{-3}$ ohm	$f_{-3db}$	9.3 kc/s

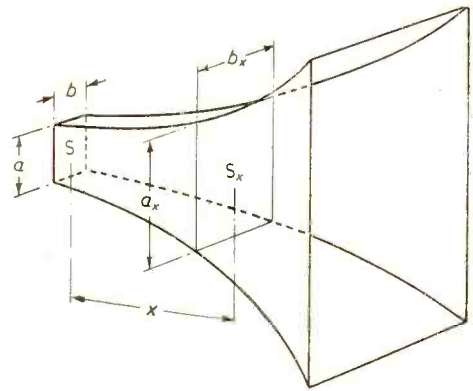
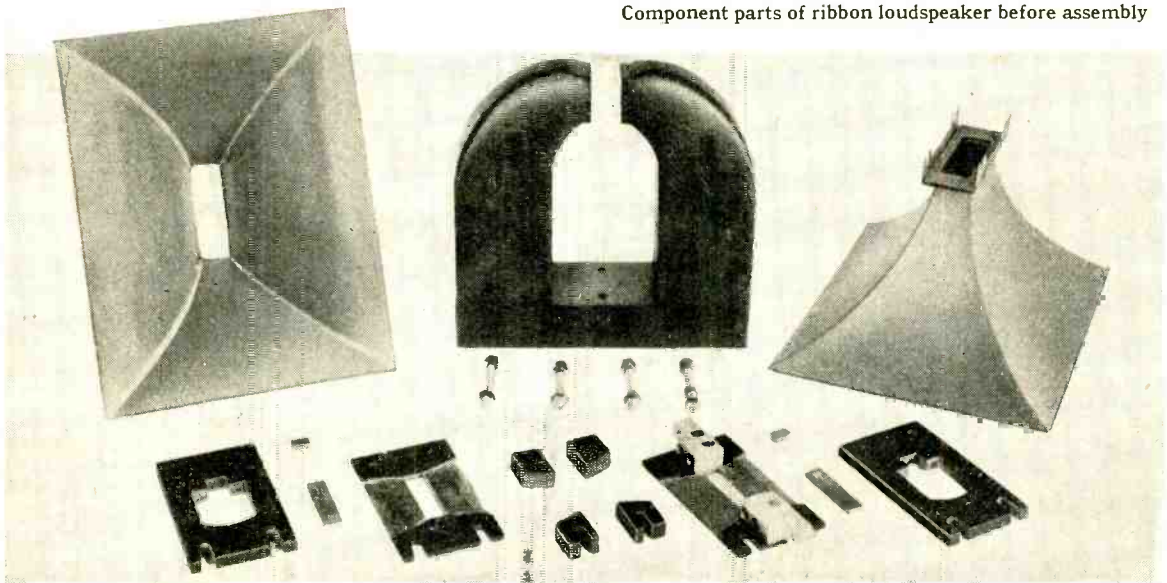

Fig. 3. Illustrating the development of an exponential horn.

Component parts of ribbon loudspeaker before assembly



for a ribbon in free air this assumption is by no means justified, and in practice horn loading is generally considered necessary. To quote from p. 120 of the reference given earlier "The primary purpose (of a horn) is to load the diaphragm at the narrow end by increasing the pressure against which it has to work and to deliver the energy it receives to the atmosphere over an area sufficiently large to avoid reflection back into the horn with consequent stationary vibration and resonance." In other words, a horn is a device for matching the diaphragm (in this case the ribbon) into the air and so ensuring efficient radiation.

The usual form of a horn is "exponential" (Fig. 3) in which the area  $S_x$  at a distance  $x$  from the small end (the throat) is related to the throat area  $S$  by the equation

$$S_x = S e^{mx} \dots \dots \dots (14)$$

In designing the horn two decisions have to be made; the value of  $m$  (i.e., the rate of flare) and the total length of the horn.

It can be shown that an exponential horn only

Fig. 4. Details of ribbon mounting and horn supports. (a) expanded section at Y-Y, and (b) partly expanded section at X-X.

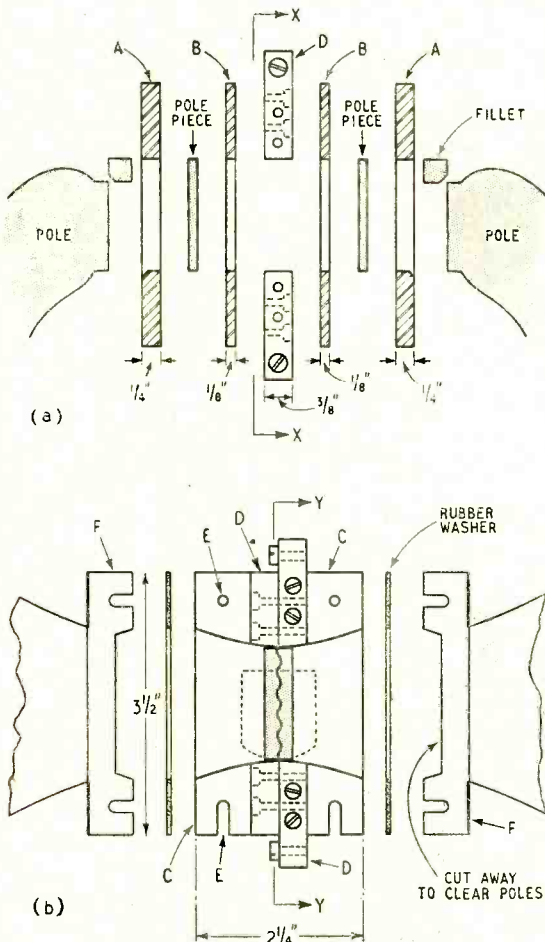

behaves as required above a critical frequency  $f_c$  which is determined by  $m$ ; in fact,

$$m = \frac{4\pi f_c}{c} \dots \dots \dots (15)$$

where  $c$  is the velocity of sound (13,500 inches per second, since we shall be working in inches for the horn dimensions). Below this critical frequency no radiation occurs, and the less rapid is the flare (i.e., the lower is  $m$ ) the lower the critical frequency. But the ribbon unit must not be allowed to work at too low a frequency, even if space for a large horn can be found, as the thin ribbon is easily overdriven. Most of the power in music and speech lies below a frequency of about 1,000 c/s so it is wise to arrange by means of a crossover network that a normal moving-coil loudspeaker which is reasonably satisfactory up to this frequency handles the range up to, say, 2,000 c/s and the ribbon unit the higher frequencies. The horn can then be designed for a critical frequency of 1,000 c/s (giving an  $m$  of 0.93 per inch) which ensures that the lowest frequency it has to handle (2,000 c/s) is well within its working range. At the same time, the flare is not so rapid as to lead to practical difficulties in cutting and bending to the right shape the horn material, and yet the horn is reasonably small.

The length of the horn is determined by considerations of the dimensions of the mouth. As pointed out above, these dimensions must be "sufficiently large to avoid reflections back into the horn . . ."; within reason the larger the mouth of the horn the better. A practical criterion is that the sides of the mouth should be about one wavelength at the lowest frequency. For the figures given above this is about 12in., leading to a horn about 6in. long.

It is not essential that the horn should be of the same cross-sectional proportions all the way along; starting from a long narrow ribbon this would give a horn of an awkward shape. Instead, the rates of flare  $m_a$  and  $m_b$  of the  $a_x$  and  $b_x$  dimensions may be different; but

$$S_x = a_x b_x = a e^{m_a x} \times b e^{m_b x} \\ = a b e^{(m_a + m_b)x} = S e^{mx}$$

and therefore  $m_a + m_b = m$ . In the present design  $m = 0.9$  giving a mouth area of about 50 square inches with a length of 5 inches. The  $a_x$  dimension expands from 1.5 inches to 8 inches in this length, so that  $m_a = 0.335$  and therefore  $m_b = 0.565$ .

**Practical Details**

**Construction.**—The magnet used originally produced a field of 9,700 gauss across a 5/8in gap between poles 1in by 1 1/4in; this was increased to 12,500 gauss by fitting pole-pieces 1 1/4in by 3/4in by 1/4in of mild steel strip. Mild steel fillets were fitted where the pole-pieces project beyond the original poles to even the field distribution.

It is obvious that a powerful magnet is necessary to produce the required flux density in such a large volume, together with the inevitable stray field. Watches and ferrous tools must be kept well away from it, and all assembly work should be done away from the normal work-bench where iron filings might enter the gap. The keeper should not be removed and replaced more often than is necessary.

The ribbon and horn supports (Fig. 4) are made of synthetic-resin bonded paper board ("Paxolin," "Tufnol," etc.). Five pieces (two A, two B and



one C) of the appropriate thicknesses are cut approximately to the right dimensions and the bolt-holes E carefully drilled. They are then bolted together and filed to size, and the bottom holes slotted as the magnet somewhat obscures them and the bolts have to be put in sideways. The pieces A are filed out to fit snugly over the poles and fillets, with the inner faces flush with the faces of the poles. Pieces B have  $1\frac{1}{2}$  in by  $\frac{3}{8}$  in holes for the extra pole-pieces, and are filed towards the edges to the contour of the horn. The centre piece is cut into four pieces C, shaped to the other horn section, allowing room for the ribbon clamps D. These are pairs of aluminium blocks of  $\frac{3}{8}$  in square cross-section; one block of each pair is screwed to one of the pieces B and extends to form a terminal post. The butting faces of these blocks are smoothed down on emery cloth on a flat surface, to ensure good contact to the ribbon.

The ribbon was obtained from a tubular paper capacitor—some search was necessary before one containing thin enough material was found! Once obtained this is cut to the correct width, but considerably longer than the final length, before removing the last layer of paper. After washing in carbon tetrachloride to remove grease, it is smoothed out on a sheet of clean glass. (The ribbon has a tendency to curl up, and fixing a piece of transparent sticky tape to each end greatly facilitates handling.) It is corrugated slightly by winding turns of 16 s.w.g. enamelled wire on a flat former, and pressing the ribbon on to the turns with a finger.

The two horns are made of about 26 s.w.g. tinplate, to the calculated dimensions, allowing for the fact that the initial part of the horn is formed by parts B and C of the ribbon supports. (Of course, the shapes to which the tinplate has to be cut are not the same as the axial cross-sections of the horns; the method of developing the required shapes is shown in Fig. 5.) After bending and soldering along the corners the small ends are soldered to channel pieces F in which appropriate rectangular holes have been cut. The sides of the channels are slotted to pass under the bolts in the main structure.

**Assembly.**—This is quite straightforward. All the parts of the main structure are assembled on the magnet, with the exception of the smaller clamping blocks and the shaped pieces C covering them. The magnet is then laid on its side and the two bolts which are now underneath temporarily inserted. The ribbon is placed in position and held by the adhesive tape on its ends while the small clamps are screwed down; excess ribbon can then be torn off. The remaining pieces C are inserted and one of the horns bolted in place, after which the other bolts can be loosened and the second horn fixed. Rubber washers cut from a car-tyre inner tube are placed between the horns and the main structure. Only brass nuts and screws should be used throughout.

**General.**—Since the ribbon impedance is so low the leads to the matching transformer must be stout and twisted together to reduce inductance, but should not be less than a foot long to allow the transformer to be mounted well away from the magnet. Also, the transformer secondary must have a low resistance and leakage inductance. As a guide, a transformer to match the above unit into 15 ohms was wound as follows:

Core: square stack of Mumetal laminations (Pattern 178, Magnetic and Electrical Alloys).

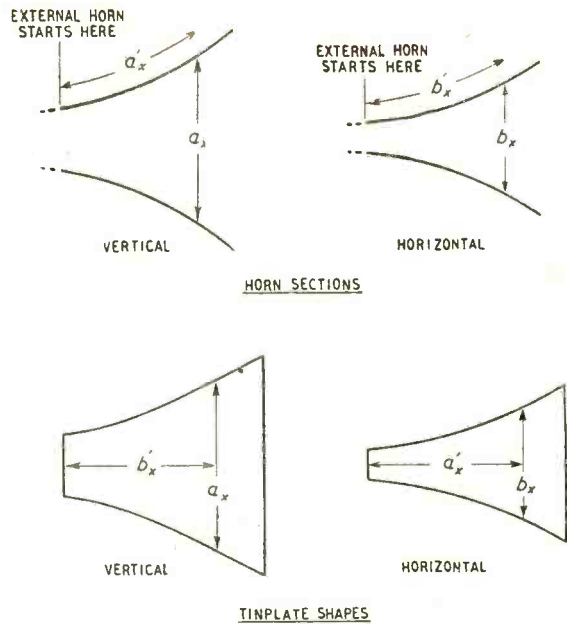
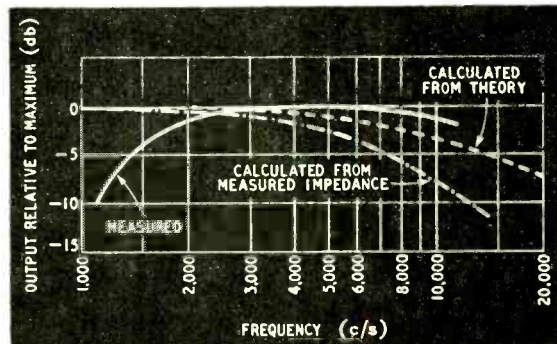

Fig. 5. Method of marking out sides of horn for cutting from flat sheet.

Fig. 6. Calculated and measured frequency response curves.



Primary: 4 layers of 10 turns each of double 20 s.w.g.

Secondary: 1 turn of 1 in wide copper strip between each primary layer (total 3 turns).

The cross-over network can be designed using basic formulae<sup>2</sup> or more simply from abacs<sup>3</sup> and should be based on a frequency of 2,000 c/s.

## Results

**Impedance Measurements.**—Measurement by a bridge method showed that for all frequencies above about 3,000 c/s the impedance of the unit was substantially that of Fig. 2(b) with the addition of an inductance L in series with  $R_1$ , where  $L = 6.9 \times 10^{-7}$  henrys,  $R_1 = 2.7 \times 10^{-2}$  ohms,  $R = 6.6 \times 10^{-3}$  ohms,  $C = 3.4 \times 10^{-3}$  farads. Below 3,000 c/s the horn is

<sup>2</sup> F. E. Ternan, "Radio Engineers Handbook," p. 249. (McGraw-Hill and Beatty and Sowerby. "Radio Data Charts" p. 81. (Iliffe and Sons).

operating near its cut-off frequency, the effect of which is that  $Z_u$  is not entirely a real quantity and the impedance of the ribbon differs from that given above. But above this frequency the agreement of the figures for R and C with theory is good. The importance of short leads is evident from  $R_1$ , and L also becomes important at the higher frequencies.

**6. Frequency Response**—Three curves are plotted in Fig. 6; one from the simple calculated impedance of Fig. 2(b), one from the measured impedance, and one measured with a calibrated microphone. The latter shows well the effect of the horn. It is not extended above 12,500 c/s as the microphone was not calibrated above this frequency, but aural impressions indicate that the response continues to fall smoothly without either peaks or a sharp cut-off. The curve for the measured impedance is somewhat misleading; strictly, it does not apply below 3,000 c/s but should fall rapidly. Allowing for this, and raising the general level of the curve so that its highest point is at 0 db, it would show closer agreement with the measured response. Otherwise the correlation between the curves is reasonable considering the experimental errors and the various assumptions made. It may therefore be concluded (a) that it is important to design the horn for a cut-off frequency at least an octave below the cross-over frequency, and (b) provided values of B and  $\tau$  as given by the simple theory are used, good results may be expected. In calculating  $\tau$  from B and  $\eta$  a value for  $\eta$  of about 0.2 should be used. In a practical unit the resistance of leads and of the connection to the ribbon itself lower the efficiency to something more nearly approaching that of a normal 12in moving-coil unit. Even so, it may be necessary to pad down the ribbon unit to match the other as has proved the case with the writer's combination; particularly as it may not be possible in practice to obtain thin enough ribbon.

**Aural Impressions.**—The improvement in high-frequency response with the ribbon unit over the writer's 12in speaker (itself considered to be good) is most marked, and has been commented on by a number of people, both technical and non-technical, musical and non-musical. Results compare very favourably with two commercial units which the writer has heard.

## PROFESSIONAL SOUND RECORDING

IN his Presidential Address at the Royal Society of Arts to the Association of Professional Recording Studios on December 5th last, the Earl of Harewood spoke of the value of direct recording to musicians as a medium for self-criticism, and of his own experiences with recording apparatus. The craft of producing good recordings was one which had to be learnt, and one essential was that the mechanism of recording should not obtrude on the performer's preoccupation with his art. Having spent large sums on initial training for his career as a musician, he would not begrudge the few pounds necessary to secure a record of his progress under the comfortable conditions of a professional recording studio. In America recording was now accepted as a routine part of orchestral rehearsals; there was ample scope for the expansion of professional recording activities in this direction in this country.

C. E. Watts (President of the British Sound Re-

recording Association) followed with a demonstration of recent progress in disc recording in which he played some remarkably fine piano recordings, made with no restriction on lateral acceleration of the groove. Unfortunately the life of such records was limited to about a dozen playings, even with modern lightweight pickups.

The future of commercial broadcasting was the topic chosen for the address by the Vice-President of the Association, Derek Faraday. After drawing a careful distinction between "commercial" and "sponsored" types of programme structure, he showed, with examples from recent B.B.C. features, how a sponsored system might be introduced without any obvious change in the character of B.B.C. programmes as at present constituted. Such a change would open up a wide field for independent professional recording studios.

Particulars of the Association of Professional Recording Studios, and the services offered to members are obtainable from the General Secretary, M. K. Howells, 14, Wynchgate, Harrow Weald, Middlesex.

## MANUFACTURERS' LITERATURE

**Schools Radio** equipment briefly described in leaflets from Audix B.B., Ltd., Hockerill Works, Bishop's Stortford, Herts.

**Car Radios** made by Ekco; short specifications for the complete range of models from E. K. Cole, Ltd., Ekco Works, Southend-on-Sea, Essex.

**Components and accessories** in a catalogue from A. F. Bulgin & Co., Ltd., Bye Pass Road, Barking, Essex.

**Radiogramophone**, Model FG50 described briefly in a specification from Kolster-Brandes, Ltd., Footscray, Sidcup, Kent.

**Batteries** for all purposes, including accumulators, catalogued in a booklet from Pertrix (Holsun Batteries, Ltd.), 137, Victoria Street, London, S.W.1.

**Loudspeakers** and accessories catalogued in an illustrated brochure from Wharfedale Wireless Works, Bradford Road, Idle, Bradford, Yorks.

**Relays** for various applications described in leaflets from Londex, Ltd., Anerley Works, 207, Anerley Road, London, S.E.20.

**Valve Data** and price list of Osram valves from The General Electric Co., Ltd., Magnet House, Kingsway, London, W.C.2.

**Sound Level Meter**, type 1400 portable instrument described in a leaflet from Dave Instruments, Ltd., 130, Uxbridge Road, Hanwell, London, W.7.

"**Always in the Picture**," an illustrated booklet describing the television activities of Pye, Ltd., of Cambridge.

**Geiger-Muller and Cathode-Ray** tubes; data sheets and a price list from 20th Century Electronics, Ltd., Dunbar Street, West Norwood, London, S.E.27.

**Multi-way Connectors** by Kabi described in a leaflet from Precision Components (Barnet), Ltd., 13, Byng Road, Barnet, Herts.

**Catalogue** of radio and electronic equipment from Holiday and Hemmerdinger, Ltd., 74-78, Hardman Street, Deansgate, Manchester, 3.

**Output Transformer** complying with the "Williamson" specification in a technical data sheet from Partridge Transformers, Ltd., Roebuck Road, Tolworth, Surrey.

**Long-playing Turntable**, an attachment for converting normal radiograms, described in a leaflet from Chancery Precision Instrument Service, Ltd., 64, George Street, London, W.1.

**Sound Equipment**; numerous applications covered in an illustrated brochure from G.E.C., Magnet House, Kingsway, W.C.2.



# Temporary Vision Aerial

*Wide-band Folded Dipole of Unusual Design at the London Television Station*

By F. D. BOLT, B.Sc., A.M.I.E.E. (Eng. Div., B.B.C.)

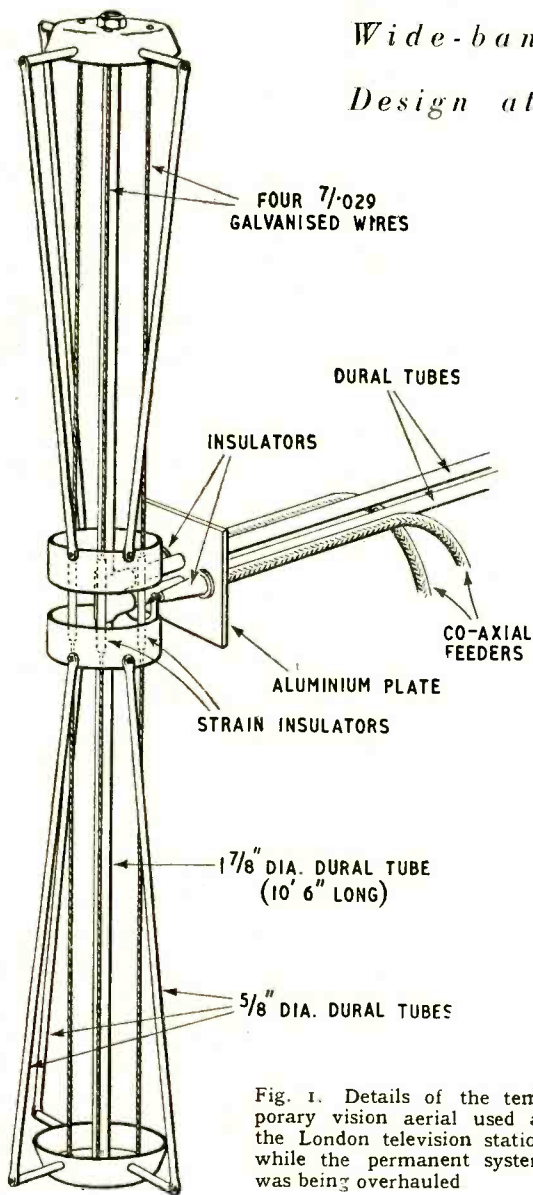

Fig. 1. Details of the temporary vision aerial used at the London television station while the permanent system was being overhauled

**D**URING last summer it became apparent that after nearly 14 years in service the Alexandra Palace vision aerial and feeder system was in need of an overhaul. This could not be done conveniently or thoroughly in the intervals between transmissions, and so it was decided to erect a temporary aerial in order to free the original installation completely. Accordingly, after two months' experimental work a simple form of folded dipole aerial was designed, constructed and erected on the top of the Alexandra Palace mast, and the service was transferred to it on 16th October for a period of six weeks, during which the main feeder was overhauled.

When conductors of equal size are used in a folded dipole (the usual arrangement) the impedance at the centre of the driven element is approximately four times that of a single straight half-wave aerial, namely 300 ohms. By using conductors that are unequal a useful range of impedances can be achieved, and this can be extended by arranging one element so that it partly shields the other. Bandwidth is dependent on the effective diameter/length ratio of the whole aerial, and for a folded dipole it is greatly improved by the inherent reactance correction.\*

Recent advances in the manufacture of v.h.f. cables have resulted in the production of a cable which will carry nearly 5 kW at 45 Mc/s with an attenuation of 0.2 db per 100 ft. The velocity factor of the cable is 0.9. The mean power output of the Alexandra Palace vision transmitter during the transmission of an average picture is about 7.5 kW, the peak white power being 17 kW. The temporary aerial was designed to be centre fed by two cables arranged as a "binocular pair," the feed point impedance being made equal to the characteristic impedance ( $2 \times 84$  ohms) of the pair in order to avoid the mechanical difficulty of inserting matching devices.

## Construction

A central element of aluminium scaffold tubing surrounded by three driven elements was used to give a driving point resistance of 168 ohms at 45 Mc/s deviating by not more than  $\pm 10$  per cent between 42 and 48 Mc/s. The variation of parallel reactance increases the impedance variation to  $\pm 20$  per cent over this frequency band. Control of the resistance value is obtained either by changing the number (coarse control) or the diameter (fine control) of the driven elements. The reactance can be varied by auxiliary connections between inner and outers near the ends of the dipole, but no improvement results from such a connection because the inherent parallel stub formed by the two elements is shorter than the optimum length. Fig. 1 gives the dimensions finally adopted, and Fig. 2 shows the aerial as it was set up during the testing period.

The vision transmitter output at Alexandra Palace is arranged for driving into a 50-ohm co-axial feeder. At some point the two 84-ohm cables had to be joined to work in parallel by making one a half wavelength longer than the other. Technically this would best be done close to the aerial in order to avoid differen-

\* R.C.A. Review, Vol. 4, p. 168, October 1939.

Fig. 2. The temporary aerial set up for testing.

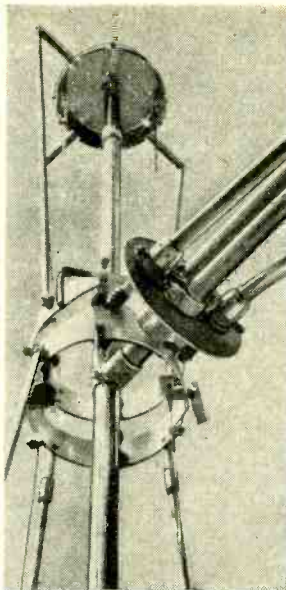
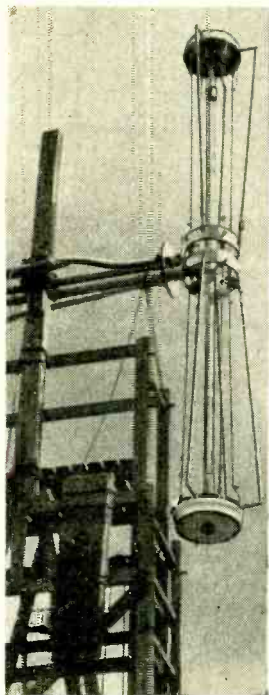

Fig. 3. This view of the temporary aerial gives some idea of the general arrangement and the manner in which the two binocular feeders are joined in.

tial phase changes along the 400-foot route due to imperfections in the cable characteristics, but mechanically it is far easier to accommodate the extra half wavelength at the transmitter end. In actual fact the cables were so little dissimilar that the mechanically easier way was adopted after trials of both.

Test transmissions produced pictures which were almost as good as those from the original aerial, the field strength over an arc from southwest through south to east being within a few per cent of that of the usual service. In the north to east direction the field strength was slightly below normal, owing to the effect of the vertical feeders. Elsewhere it closely approached that of the original system and when the aerial first came into temporary service the change-over was hardly noticed in most areas. The centre of the temporary aerial was some 30 ft higher than the old.

### Aerial Improvisations

A good deal of improvisation was exercised in the construction of the aerial in order to expedite the job. Scaffold tubing and clamps were used where possible and aluminium saucepan blanks were found to be ideal for end fittings and centre connections. The only erection difficulty was in connecting the v.h.f. cables to the aerial after it had been mounted on the pole as it was not convenient to assemble them before the aerial was erected.

The two cables were hauled up the mast with little trouble and cleated to a steelwire rope.

Fig. 3 is a close-up view of the aerial when mounted on its pole (not shown) and seen also is the circular aluminium plate to which the feeders and stand-off insulators are secured.

## AMPLIFIERS FOR DISC RECORDING

### Lecture-Demonstration at the B.S.R.A.

SOME useful criteria for the specification of amplifiers for high-quality recording were given by H. D. McD. Ellis, M.A., M.I.E.E., at a meeting of the British Sound Recording Association in London on November 24th last.

The frequency response of B.B.C. recording amplifiers was 50 to 10,000 c/s  $\pm$  1 db with a gradual rather than a sharp cut-off. Transformers were the limiting factor and the economic upper limit of 10 kc/s was dictated by the characteristics of "music" land lines. Any reduction of frequency response should be made at both ends of the scale; the product of high and low frequency limits should approximate to 500,000 with a centre in the region of 700 to 800 c/s. Distortion was best assessed by calculating the r.m.s. sum of harmonics in per cent, with each ( $n$ th) harmonic weighted by multiplying by  $n^2/4$ . On this basis a figure of 5 might well represent the borderline between high and medium quality.

High-quality transducers (microphones and cutter heads) were usually insensitive and overall power gains of the order of 120 db were necessary. At this level of amplification, noise was a major problem with Johnson thermal noise as the limiting factor. In general, hum level up to 6 db worse than Johnson noise could be tolerated; hand-picked valves were necessary to ensure adequate freedom from microphony.

The output required for disc recording was considerable—of the order of 100 VA in the B.B.C. Type D equipment. Cutter heads with high inductance presented matching difficulties and called for low voltage and high current at low frequencies, high voltage and low current at high frequencies. It was better to express the output in volt-amperes rather than in watts.

After discussing the limitations of feedback, Mr. Ellis went on to show how it could be applied with advantage to include distortions in the recording cutter head. In the B.B.C. Type B head a second coil monitors the rate of change of flux in the magnetic circuit and provides a voltage which is fed back to an intermediate stage of the amplifier to compensate for distortion of the flux waveform. This gives a close approximation to the ideal of feedback controlled by the actual motion of the cutter point.

Volume compression was necessary in order to reduce actual sound level changes to the range of 45 db, which could be accommodated in disc recording. Manual control by a skilled operator was preferable to automatic compression, since some distortion was inherent in the non-linear characteristic required for instantaneous control. The virtue of manual control was intelligent anticipation, but some safeguard for carelessness was necessary, and in the amplifier used in the Type D equipment an auxiliary circuit, biased to cut-off at normal operating levels, was arranged to provide automatic overload prevention for excessive peaks.

After a general description of a typical B.B.C. recording channel, Mr. Ellis gave a demonstration of some high-quality piano recording, and showed the merits of the latest type of volume indicating meter.



# WORLD OF WIRELESS

Beveridge Report ♦ New Governors ♦ European Broadcasting Problems ♦ B.B.C. Television Policy ♦ Steel C.R. Tubes

## Broadcasting Inquiry

THE last meeting of the Broadcasting Committee, which was appointed in 1949 to consider, under the chairmanship of Lord Beveridge, the constitution and control of the United Kingdom broadcasting service, was held on December 15th for the signing of the report. It is understood that this report, which will summarize the oral and written evidence obtained from a considerable number of witnesses and give the findings of the eleven members, will be presented to the Government soon after the Christmas recess.

## B.B.C. Governors

TWO new Governors of the B.B.C. have been appointed—I. A. R. Stedeford, who was a member of the Beveridge Broadcasting Committee and was previously a member of the Television Advisory Committee, and Francis Williams, who, during the war, was Controller of News and Censorship at the Ministry of Information. Their term of office is for one year only; the B.B.C. Charter ends on December 31st, 1951. Their appointment brings the number on the Board of Governors, which controls B.B.C. policy, up to eight.

Lord Tedder, who was appointed a Governor last year, has been made vice-chairman of the Board in succession to the Dowager Marchioness of Reading, whose term of office has ended.

## I.F. Problems

THE problem of the choice of intermediate frequencies for superhets, created by the introduction of the Copenhagen Plan, which was dealt with by G. H. Russell in our September, 1949, issue, has been tackled by the Technical Centre of the European Broadcasting Union (U.E.R.).

In the November issue of the U.E.R. *Bulletin* in which there is an article on the subject, it is stated that the members of the Union are, so to speak, "manufacturers and suppliers" of modulated waves, and as such they need not, in principle, concern themselves with what their "customers" chose ultimately to do with their products. If, on the other hand, it can be shown that a judicious arrangement of broadcasting stations in Europe results in reception with a minimum of

"whistles," then it is considered by the Union that its members should not dissociate themselves entirely from the problem.

With a view to undertaking a closer study of the problem the Union has sent a questionnaire to associations representative of receiver manufacturers in Belgium, France, Italy, Switzerland and to B.R.E.M.A. in this country.

## Italian F.M.

LIKE Germany, where in each of the three Western Zones there has been established a f.m. network to alleviate the congestion in the medium-wave band, the Italian broadcasting service (Radio Audizioni Italiano) has introduced a chain of eight f.m. stations to radiate the country's Third Programme. To meet the needs of those outside the service areas of the eight transmitters the programme is also being radiated on four wavelengths in the short-wave band with amplitude modulation.

The new transmitters, which operate on frequencies ranging from 90.9 to 99.9 Mc/s, are located in Bologna, Florence, Genoa, Milan, Naples, Rome, Turin and Venice.

## Television Progress

WHEN outlining the B.B.C.'s policy regarding television at a recent conference, the Director General, Sir William Haley, quoted figures showing the increased amount

of capital expenditure on the service—from £74,000 in 1947-1948 to £914,000 in the current financial year and an estimated £1,202,000 next year. He estimated that 60 per cent of the Corporation's income in the next three years will be devoted to the development of the television service.

On the question of the international exchange of programmes, it was learned that a television transcription service, similar to that already existing for sound broadcasting, is being introduced by the B.B.C. to provide British programmes for other European countries.

When dealing with the question of the transmission of the Test Card at times suitable for home constructors to test their sets, it was stated that the main difficulty is the shortage of camera equipment and studios, which are used for rehearsals out of transmitting hours. The difficulty is so acute that the teleciné camera is not infrequently used for the present Test Card transmissions.

The progress report on the building of the Holme Moss transmitter shows that at the end of December the mast—which, like that at Sutton Coldfield, will incorporate a slotted v.h.f. aerial—in case a v.h.f. transmitter for sound broadcasting is installed—has risen to some 600ft—it will eventually be 750ft. A stand-by mast, 150ft high, with a smaller aerial, is being erected in case there is trouble with the main mast.

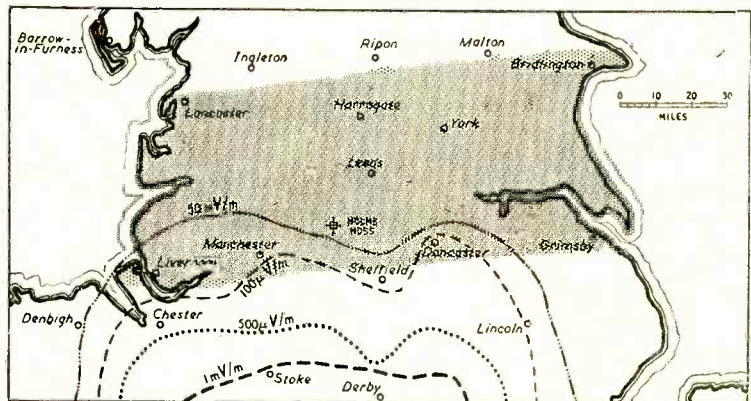

**NORTHERN TELEVISION.**—The B.B.C. states that the area within which reception of Holme Moss can be relied upon is expected to be roughly rectangular, as indicated on this map. To show the probable overlap of the Midland and Northern service areas some of the field-strength contours of the Sutton Coldfield transmitter are included.

Medium-power stand-by vision and sound transmitters are also being installed as a precautionary measure, and as a further precaution, the power supply for the station is coming from two sources. As already announced, the station will receive the London transmissions from Sutton Coldfield by coaxial cable.

The 35-kW Marconi vision transmitter will operate on 51.75 Mc/s and the 12-kW sound transmitter on 48.25 Mc/s.

The second of the converted film studios at Lime Grove, Shepherd's Bush, West London, has been brought into use by the B.B.C. It

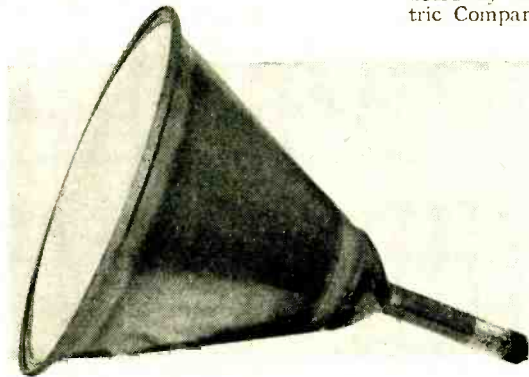

The English Electric 16-in cathode-ray tube, with steel body fused to glass face-plate and neck, has been designed for large-scale production.

has a floor area of 5,500 sq ft and is equipped with four Pye Photicon cameras. All the control gear and ancillary equipment for the sound and vision channels and the telecine camera are in two adjoining rooms. The permanent wiring from the Apparatus and Control Rooms to the eight camera socket outlets conveniently disposed around the studio has been carried out in special cable provided by B.F. Callenders' Cables.

### Scientific Instruments

THIS year's Physical Society's exhibition of scientific instruments and apparatus—the 35th—will occupy two buildings—the main building of the Royal College of Science and the nearby Huxley Building, South Kensington. It opens on April 6th, when the morning session will be for members of the Society, and on the 7th, 9th, 10th and 11th for holders of admission tickets obtainable from the Physical Society, 1, Lowther Gardens, Prince Consort Road, London, S.W.7. These tickets, supplies of which will be sent to learned societies, are valid for either the morning or afternoon sessions but not for a specified day. The morning sessions will be from 10 a.m. to 1 p.m. and the afternoon from 2 to 9 p.m., with the exception of the 7th and 11th when the exhibition will close at 5 p.m.

A handbook of the exhibition containing full descriptions of the exhibits will be obtainable from the Society early in March.

### Steel C.R. Tubes

CATHODE RAY tubes with spun-steel conical bodies and glass face-plates and necks are now being manufactured by the English Electric Valve Company. It is claimed that the new tube is lighter but at the same time more robust than its all-glass counterpart, and above all, that the design lends itself much better to modern mass-production techniques. The face-plate is nearly flat, thus increasing its effective area.

One size only—16 in.—will be available. The tube is being marketed by the parent English Electric Company.

### Science Centre

FOR some years negotiations have been going on for the establishment of a centre in London which would provide adequate accommodation for the learned societies. In the House of Commons on November 21st the Lord President of the Council announced that it had been possible to overcome the remaining obstacles for the adoption of the proposals originated by the Royal Society for a British Science Centre in London.

Provision will be made for accommodating in the Centre the Patent Office and its Library, the D.S.I.R. and other Government scientific organizations as well as providing new quarters for many of the leading scientific societies.

The actual site has not been announced.

### International Acoustics

AS a result of the proposal put forward at an international acoustical meeting in Marseilles some months ago, a new journal, with the title *Acustica*, is being sponsored jointly by the Acoustics Group of the Physical Society in this country and similar organizations in France and Germany.

The journal, which will cover musical, architectural, physiological and biological acoustics, will be published in Switzerland in either French, German, or English with abstracts in the other two languages. The British representative on the

Editorial Board is Dr. E. G. Richardson, Physics Department, King's College, Newcastle-on-Tyne, 2.

### Television Cables

OUR oft-repeated claim that the British 405-line television system, with a bandwidth of 3 Mc/s. is the only one that is suitable for transmission over the existing international telephone cables, was reiterated by a sub-committee of the International Telephone Consultative Committee (C.C.I.F.) at a recent meeting in Geneva. It was emphasized that it would be necessary to double the number of repeaters for the "European" 625- and French 819-line systems.

### East African Communications

AN experimental v.h.f. beam radiotelephone link between Nairobi and Nakuru which has been in use for more than a year has proved so successful that the East African Posts and Telegraphs Department plan to install similar equipment linking the major towns in Kenya, Uganda and Tanganyika. During this year radio equipment will be installed linking the telephone systems of Kampala and Jinja, Jinja and Nakuru and Tanga and Dar-es-Salaam. By 1952 Nairobi will be linked with Mombasa, Mombasa with Tanga, and Dar-es-Salaam with Dodoma.

A team of radio engineers is at present carrying out a survey in the coastal sector of East Africa, the results of which should add much to the knowledge of v.h.f. propagation in the tropics. Both the experimental gear and field survey equipment—which is mounted in motor vehicles to enable tests to be undertaken in any part of East Africa—were provided by Marconi.

### G.R.S.E.

THE need to educate the public to the fact that radio servicing is a highly skilled job and also to eliminate "the dabbler and self-styled expert" is stressed in the recently produced prospectus of the Guild of Radio Service Engineers.

There are four classes of membership of the Guild, the main objects of which are to improve the status of those engaged in the "repair and maintenance of radio, television and similar electronic apparatus"; they are: (a) Full Member—who must be over 21, hold an approved certificate or have served for five consecutive years as a service technician; (b) Associate Member—who, although over 21, has served for less than five years; (c) Apprentice—serving under indenture; and (d) Improver. Membership is not open to principals or partners of firms or to those trading upon their own account.



Particulars of the Guild, which is registered under the Trade Unions Acts and has branches in Northern Ireland, Scotland, N.E. and N.W. England, are obtainable from the Honorary General Secretary, H. Hill, 2, Stevenson Street West, Accrington, Lancs.

It may be remembered that the G.R.S.E. is joint sponsor with the Radio and Television Retailers' Association of the Radio Service Trade Register.

## B.B.C. Appointments

ANOTHER rearrangement of executives and departments in the Engineering Division of the B.B.C. is announced. A newly formed group—composed of the Planning and Installation Department and the Designs Department—is to be known as the Engineering Projects Group. F. C. McLean, who has been Head of the Engineering Services Group for the past 18 months, becomes Head of the new group and is succeeded by E. L. E. Pawley, who was his assistant. Mr. McLean joined the Corporation in 1936 after 11 years with Standard Telephones and Cables and was largely responsible for the erection of many of the B.B.C. transmitters built during the war. Mr. Pawley has been with the B.B.C. since 1931.

T. C. Macnamara, who had been with the Corporation since 1923, and who had, since 1947, been Head of the Planning and Installation Department, has resigned from the Corporation (see "Personalities") and is succeeded by A. N. Thomas, his assistant. Mr. Thomas joined the Research Department of the B.B.C. in 1926 and in 1938 became assistant to the Superintendent Engineer (Transmitters).

## PERSONALITIES

T. C. Macnamara, who, as announced above, has resigned from the B.B.C. where he was in charge of the department responsible for planning, commis-



T. C. MACNAMARA

sioning and installing all the equipment used by the Corporation, has joined Scophony-Baird as Director of

Engineering and Production. During his 27 years with the B.B.C. he was largely concerned with the establishing of transmitting stations, including Droitwich, Alexandra Palace and Ottringham. He was Secretary to the 1943 Television Committee under the chairmanship of Lord Sankey.

Air Comdre. B. D. Nicholas, who has been appointed Air Officer Commanding No. 27 Group, R.A.F. Technical Training Command, has, since 1946, successively held the posts of Inspector of Signals, No. 90 Group; Deputy Director of Radio at the Air Ministry and Director of Signals (Organization).

Percy Good, C.B.E., who had been Director of the British Standards Institution since 1939, died on December 2nd at the age of 70. He was appointed Assistant Secretary of the British Engineering Standards Association—now the B.S.I.—in 1913 and was president of the I.E.E. in 1947.

## IN BRIEF

**Synthetic Radio** and radar equipment is used in the training of air traffic control officers at the Ministry of Civil Aviation's A.T.C. School at Hurn Airport, in addition to normal courses on telecommunications and radar. Comprehensive training on all aspects of air traffic control is given both to new recruits and established M.C.A. officers, and since 1948 when the school opened 479 British and 23 Overseas officers have passed through it. Arriving at Hurn by air, *Wireless World* was safely and efficiently "talked down" on to the runway by pupils who were gaining actual operational experience of radar in the Airport's G.C.A. van.

Iceland's new 5-kW transmitter at Eidar—operating on 611 kc/s—was provided by Marconi's who supplied the original 1-kW installation which it replaces. The Iceland State Broadcasting Service has now placed an order with the company for a 5-kW transmitter for a new station at Akureyri which, under the Copenhagen Plan, shares the 737-kc/s channel with Spain, Palestine and Poland. Iceland has also ordered a 20-kW long-wave transmitter for erection on the same site as the existing 100-kW long-wave station at Reykjavik.

**S.W. Listening.**—The annual short-wave listening competitions organized by the International Short Wave Club will be held in February. In the first of these, contestants have to log between February 4th and 18th South and Central American and West Indian stations operating on c.w. or 'phone in the 14- and 28-Mc/s bands. In the second contest competitors have to log, during the four weekends in February, short-wave broadcasting stations in the same areas. Entrance forms and full details are available from I.S.W.C., 100, Adams Gardens Estate, London, S.E.16.

**Yachtsmen** among our readers may like to know of the introduction of the *Yachting World* Diary issued for our associated journal *Yachting World* by our Publisher, priced 9s 2d, including purchase tax. The material in the 52 pages of reference data ranges from the International Code of Signals in full colour to the London Underground System and includes the morse code and the times of B.B.C. weather forecasts.

## INDUSTRIAL NEWS

A South African Company is being formed jointly by E.M.I. and H. Polliack & Co. of South Africa and a factory is being erected in Johannesburg for the manufacture of gramophone records. It is understood that it is intended at a later stage to extend the factory to include the manufacture of other E.M.I. consumer goods, including broadcast receivers and radio-gramophones.

**U.N. Television.**—Tenders for television equipment, presumably to American standards, called for by the United Nations Headquarters, Lake Success, include three complete mobile camera chains and vision control equipment. Details are available from The Commercial Relations and Exports Department (Industries Branch), Board of Trade, Room 1080, Thames House North, Millbank, London, S.W.1 (Reference C.R.E.(IB)7218/50).

**New studios** for the broadcasting service in Hong Kong—the technical side of which is the responsibility of Cable and Wireless—are to be equipped with seven Marconi control consoles.

Marconi International Marine Communication Co. has acquired new premises at 36, Broad Street, Peterhead, from which all Marconi marine business in the port will be conducted (Tel.: Peterhead 376).

A.B. Metal Products, Ltd., have found it necessary to extend their works at Yuysloeth, Abercynon, Glamorgan, into which they recently moved, and the factory now covers an area of 72,000 sq ft.

## MEETINGS

### Institution of Electrical Engineers

**Radio Section.**—Discussion on "How Reliable is a Radio Valve?" to be opened by G. H. Metson, Ph.D. M.Sc., B.Sc.(Eng.), at 5.30 on January 22nd at Savoy Place, London, W.C.2.

**Cambridge Radio Group.**—"The Use of Saturable Reactors as Discharge Devices for Pulse Generators," by W. S. Melville, B.Sc.(Eng.), at 8.15 on January 16th at the Cavendish Laboratory.

**South Midland Radio Group.**—Informal lecture on "The Operation and Maintenance of Television Outside-Broadcast Equipment" by T. H. Bridgewater at 6.0 on January 29th at the James Watt Memorial Institute, Great Charles Street, Birmingham.

**Reading (Berks) District.**—"Trends of Development in Radiocommunication" by Professor Willis Jackson, D.Sc., D.Phil., at 7.0 on January 22nd at the Great Western Hotel, Reading.

### British Sound Recording Association

"Design Requirements for Magnetic Recording Tape" by P. T. Hobson at 7.0 on January 19th at the Royal Society of Arts, John Adam Street, London, W.C.2.

### Television Society

**Leicester Centre.**—"Television from Calais" by W. D. Richardson (B.B.C. Television Service) at 7.0 on January 10th at the Leicester College of Technology, The Newarke, Leicester.

## Radio Research

### Report of the Radio Research Board

IT is seventeen years since a report on the activities of the Radio Research Board has been issued as a separate publication, so that the one covering the period 1933 to 1948, which is just published by the Stationery Office (price 2s.), is of particular interest.

"Radio Research 1933-1948," as it is called, includes in its 60 pages not only the official report of the Board, of which Sir Stanley Angwin is chairman, but also a survey of the investigations carried out under the direction of the Board between 1934 and 1947; the report of the Director of Research—Dr. R. L. Smith-Rose—for 1948; and appendices giving the membership of the Board, the papers emanating from the Radio Division of the N.P.L., and the constitution of the Board's various committees. For the sake of continuity with the earlier reports, the Board gives a brief account of its activities from 1933-1945, but the major part of the publication is devoted to a more detailed survey of the post-war period.

The report records that a considerable amount of time is devoted to the study of the ionosphere and that this part of the Board's work is being extended. This work has been centred on the Radio Research Station, Slough, where these measurements have been conducted for many years past. In addition, however, regular observations of a similar type have been made at the sub-stations at Fraserburgh in Aberdeenshire, and at Port Stanley in the Falkland Islands; while during the latter part of 1948 preparations were made for a similar ionospheric observatory to be set up at Singapore.

Following the recommendation of the British Commonwealth Scientific Official Conference in 1946, the possibility of installing ionospheric recording stations in Graham Land has been explored and an observatory is to be established on Deception Island.

The present research programme includes an investigation of the communication possibilities of the shorter wavelengths now being used for radio-telephone relay links and television, and valuable data have already been accumulated.

Research into the characteristics and sources of atmospheric noise has been developed into a world-wide survey in co-operation with Australia and the United States of America. Sixteen Service and commercial stations now make a schedule of hourly observations over the frequency band 2.5-20 Mc/s. The investigation is being extended to the low-frequency range of 15 to 500 kc/s, and a network of observation stations covering this range of frequencies is being established.

### Horn Loading

THE potentialities of horn loading were demonstrated at a lecture by R. L. West, B.Sc., A.M.Brit.I.R.E., on "Progress in Loudspeaker Design" given to the British Institution of Radio Engineers on December 18th last, when a 2½-in diameter unit of the type often used for monitoring purposes in communication receivers was coupled by an extension piece to an early Voigt tractrix horn with 4ft square mouth. Remarkably good quality of reproduction with a full round bass response resulted,

and a comparison of the same unit as a direct radiator bordered on the ludicrous.

This was, of course, a rather special case, and the more advanced types of direct radiators among the thirty-odd loudspeakers demonstrated gave a very good account of themselves, particularly when mounted in acoustically designed cabinets. Starting with a pleated-diaphragm loudspeaker of pre-1930 vintage, the principal developments in loudspeaker practice were traced—moving coil drive, twin diaphragms, multiple units, duode drives and concentric horn and cone loudspeakers for wide-range reproduction.

The distribution of high frequencies was discussed in some detail and the use of multi-cellular horns, solid reflectors of the Voigt and Mordaunt type, and slot diffusers were demonstrated. The latter consists of a vertical slot aperture in a baffle placed in front of the cone and the diffraction of sound from a saturated diode source, normally exhibiting a well-marked beam in the upper register when reproduced through a simple cone unit, was one of the most striking experiments of the evening.

The discussion which followed produced questions on many aspects of sound reproduction including the probable magnitude of the Doppler effect in causing intermodulation between high and low frequencies when radiated by a single diaphragm. Mr. West thought that this effect was often exaggerated and that before amplitudes which might make it aural were reached, other distortions due to non-uniformity of field in the magnet gap would have made their appearance.

### Piezoelectric Pickups

A PROPHECY that in five years time ceramic aggregates of the strontium-barium titanate type might displace Rochelle salt as the principal material for making crystal pickup elements was made by S. Kelly in a lecture to the British Sound Recording Association on December 20th last. Much work remained to be done before a piezoelectric ceramic of adequate stability could be put into production, and means devised for safeguarding it against fracture. He compared its inherent strength to a piece of fur from the lining of a kettle and pointed out that because of its high mechanical impedance elements of only 0.005in thickness could be used in pickup movements. The chief advantages of this material over Rochelle salt were resistance to humidity changes and high dielectric constant.

Recent advances in crystal pickups were reviewed and a design described in which a narrow crystal torsion element, free at both ends, is embedded in a plastic gel of optimum viscosity to give an evenly distributed load, presenting to the needle point the equivalent of a properly terminated transmission line. The reflected mechanical impedance at the stylus point was reduced by the use of a cantilever mounting and record wear had proved to be remarkably low. The pickup had given very good results with long-playing records in which the problem of tracking was made more difficult than on 78-r.p.m. records because of the limitation of downward pressure imposed by the new plastic materials used, and the higher relative velocity of recording at high compared with medium and low frequencies—about 10db between 1,000 and 10,000c/s.



# Societies and Clubs

## List of Radio Groups in the British Isles

IT is now nearly three years since we last published a list of amateur societies and, as the number of such organizations on our records has almost doubled, it is considered opportune to issue a revised list. Arranged in alphabetical order under towns, the name of the club, and in some cases the club call sign, is followed by that of the secretary from whom details of the society's activities may be obtained. Clubs which are affiliated to the Radio Society of Great Britain are indicated by an asterisk. We shall be pleased to receive details from the secretaries of active societies which may have been inadvertently omitted from this list.

**ABERDARE.**—Rhigos and District Radio Club (GW3FFE).—F. Hamer, 7, Neath Road Bungalows, Rhigos, Aberdare, Glam.

**ABERDEEN.**—Aberdeen Amateur Radio Society\* (GM3BSQ).—G. M. Jamieson, 66, Elmfield Avenue, Aberdeen.

**ASHTON-UNDER-LYNE.**—Ashton-under-Lyne and District Amateur Radio Society\*.—N. H. Brown, 13, Corporation Road, Audenshaw, nr. Manchester.

**AYLESBURY.**—Aylesbury and District Radio Society\*.—J. G. Penrice, 31, Prebendal Avenue, Aylesbury, Bucks.

**BALDOCK.**—Baldock and District Radio Club\* (G3AXP).—E. W. Edwards, 104, Icknield Way, Letchworth, Herts.

**BARNSELY.**—Barnsley and District Amateur Radio Club. —J. J. Rose, 21, Swift Street, Barnsley, Yorks.

**BASINGSTOKE.**—Basingstoke and District Amateur Radio Society.—L. S. Adams, 10, Bramblys Drive, Basingstoke, Hants.

**BATH.**—Admiralty Electronics Society\* (G3BPU).—D. Houston, D.E.E. Dept., Admiralty, Bath, Som.

**BELFAST.**—City of Belfast Y.M.C.A. Radio Club\* (G16YM).—S. H. Foster, 31, Belmont Park, Belfast.

**BERWICK-ON-TWEED.**—Berwick-on-Tweed Radio Club.—W. Baker, 4, Devon Terrace, Berwick-on-Tweed, Northumberland.

**BIRKENHEAD.**—Wirral Amateur Radio Society\*—A. H. Watts, 38, Sandymount Drive, Wallasey, Ches.

**BIRMINGHAM.**—Birmingham and District Short-Wave Society.—W. V. Shepard, 174, Gristhorpe Road, Selly Oak, Birmingham, 29.

**Kynoch Radio and Television Society\*.**—G. E. Nicholls, 20, Merriens Close, Great Barr, Birmingham, 22A.

**Midland Amateur Radio Society\*.**—H. B. Bligh, 52, Norman Road, Birmingham, 31.

**International Radio-Controlled Models Society.**—G. F. Golding, 32, Beechfield Road, Smethwick, Staffs.

**Slade Radio Society\*.**—C. N. Smart, 110, Woolmore Road, Erdington, Birmingham, 23.

**BLACKPOOL.**—Blackpool and Fyde Amateur Radio Society.—H. D. Ashworth, 5, Albion Avenue, Blackpool, Lancs.

**BOGNOR.**—West Sussex Short-Wave and Television Society.—R. D. Holland, "Maybury," Aldwick Gardens, Bognor, Sussex.

**BOLTON.**—Bolton and District Radio Society.—N. Moorcroft, 3, Beaconsfield Street, Bolton, Lancs.

**BOURNEMOUTH.**—Bournemouth and District Amateur Radio Club\* (G3AYG).—T. C. White, Chester House Hotel, Chine Crescent, Bournemouth, Hants.

**Bournemouth Radio and Television Society\* (G3FVU).**—F. G. Hamsphere, 55, Maclean Road, West Howe, Bournemouth, Hants.

**BOVINGDON.**—Bovingdon Airport Club Amateur Radio Section.—J. D. Lord, Police Station, Bovingdon, Herts.

**BRADFORD.**—Bradford Amateur Radio Society\*.—V. W. Soven, "Rushwood," Grange Park Drive, Cottingley, Bingley, Yorks.

**BRIGHTON.**—Brighton and District Radio Club.—L. Holden, 17, Bartington Road, Brighton, Sussex.

**East Brighton Short-Wave Club.**—W. Jardine, 52, Kipling Avenue, Woodingdean, Brighton, Sussex.

**BRISTOL.**—Bristol and Bath Television Club.—C. J. Floyd, "Leagarth," Margaret Road, Bishopsworth, nr. Bristol, Glos.

**Bristol and District Short-Wave Listeners' Club (G3GTS).**—N. G. Foord, 71, Brynland Avenue, Bristol, 7, Glos.

**BURNHAM.**—Burnham and Highbridge Amateur Radio Society.—T. N. Carter, c/o Post Office Radio Station, Highbridge, Som.

**BURTON-ON-TRENT.**—Burton and District Radio Society.—E. B. Hardy, "Hill Cottage," Dunstall, nr. Burton-on-Trent, Staffs.

**BURY.**—Bury and District Radio Society (G3BRS).—R. H. McVey, 46, Holcombe Avenue, Elton, Bury, Lancs.

**CAMBRIDGE.**—Cambridge and District Amateur Radio Club.—T. A. T. Davies, "Meadowside," Comberton, Cambridge.

**Cambridge University Wireless Society\*.**—F. S. Williamson, 42, South Road, Histon, Cambs.

**CANNOCK.**—Cannock Chase Radio Society.—D. M. Whitehouse, 69, Church Street, Cannock, Staffs.

**CARLISLE.**—Carlisle Amateur Radio Society.—J. Ostle, 2, Outgang, Aspatria, Carlisle, Cumberland.

**CATTERICK.**—Catterick Amateur Radio Club\* (G3C10).—L/Cpl. Phelps, Catterick Amateur Radio Club, c/o 2, Sqn., 1st T.R., Loos Lines, Catterick Camp, Yorks.

**CHATHAM.**—Medway Amateur Receiving and Transmitting Society\* (G2FJA).—S. A. C. Howell, 39, Broadway, Gillingham, Kent.

**CHELTENHAM.**—Cheltenham Amateur Radio Society\* (G3GPW).—E. W. Humphries, 136, Whaddon Road, Cheltenham, Glos.

**CHESTER.**—Chester and District Amateur Radio Society\* (G3G1Z).—W. Lloyd, 124, Tarrin Road, Chester.

**CHIPPENHAM.**—Chippenham and District Short-Wave Club.—W. A. Henson, 12, Filton Way, Chippenham, Wilts.

**CLECKHEATON.**—Spen Valley Radio and Television Society\*.—N. Pride, 100, Raikes Lane, Birstall, nr. Leeds, Yorks.

**COVENTRY.**—Courtaulds Amateur Radio Group\*.—W. P. Stevens, Courtaulds, Ltd., Foleshill Road, Coventry, Warwick.

**Coventry Amateur Radio Society\* (G2ASF).**—K. G. Lines, 142, Shorncliffe Road, Coventry, Warwick.

**CRANWELL.**—R.A.F. Amateur Radio Society\* (G8FC and G3DBQ).—N. Davis, 37, North Parade, Sleaford, Lines.

**DERBY.**—Derby and District Amateur Radio Society\* (G3ERD).—F. C. Ward, 5, Uplands Avenue, Littleover, Derby.

**Derby Wireless Club.**—A. W. Elliott, "Chilvern," 46, Robin Croft Road, Alles-tree, Derby.

**DONCASTER.**—Doncaster and District Amateur Radio Society\* (G3CBM).—H. Flintham, 59, Burton Avenue, Babby, Doncaster, Yorks.

**DORKING.**—Dorking and District Radio Society\* (G3CZU).—J. Greenwell, 7, Sondes Place Drive, Dorking, Surrey.

**DUBLIN.**—Irish Radio Transmitters' Society.—Capt. A. C. Woods, 17, Butterfield Crescent, Rathfarnham, Co. Dublin.

**DUNFERMLINE.**—Dunfermline Radio Society\*.—D. Leah, 14, Billwood Terrace, Rosyth, Fife.

**EASTBOURNE.**—Eastbourne and District Radio Society\*.—R. F. Nugent, Field House, Windmill Hill, nr. Hailsham, Sussex.

**EAST GRINSTEAD.**—East Grinstead Radio and Television Society.—E. C. Cooper, "Heatherlea," Cranston Road, East Grinstead, Sussex.

**ECCLES.**—Eccles and District Radio Society\* (G3GX1).—E. Rayson, 11, Hartington Road, Winton, Lancs.

**EDINBURGH.**—Edinburgh Amateur Radio Club\* (GM3HAM).—A. G. M. Bruce, 89, Marchmont Road, Edinburgh, 9.

**Lothians Radio Society.**—I. Mackenzie, 41, Easter Drylaw Drive, Edinburgh, 4.

**EXETER.**—Exeter and District Radio Society.—E. M. Wills, "Moor View," Wrenford's Lane, Exeter, Devon.

**FALMOUTH.**—West Cornwall Radio Club\*.—R. Trewarvis, 10, Trevethan Rise, Falmouth, Cornwall.

**FARNBOROUGH.**—R.A.E. and Farnborough District Amateur Radio Society\*.—J. St. C. T. Ruddock, 80, Byworth Estate, Farnham, Surrey.

**FORFAR.**—Forfar and District Amateur Radio Club\* (G3GBZ).—A. F. Ferguson, 3, Osnaburg Street, Forfar.

**GATESHEAD.**—Gateshead and District Amateur Radio Club\*.—J. Blackie, 109, Brighton Road, Gateshead, 8, Co. Durham.

**GERRARDS CROSS.**—British Amateur Television Club.—M. W. S. Barlow, Cheyne Cottage, Dukes Wood Drive Gerrards Cross, Bucks.

# Vector Diagrams

## 1.—Beginning with the Circuit

By "CATHODE RAY"

SOME readers seem to have found "Miller Effect"\* rather heavy going when it came to the vector diagrams. It was pointed out to me that not everybody knows how to apply vector diagrams to valve circuits, nor even where to find simple instructions, and could I do something about it.

Always willing to oblige, I started off—and found I had used up something like the month's ration of paper before valves came into it at all! For on considering the matter I became convinced that at least half the trouble had to do with vector diagrams themselves rather than with their application to valve circuits. True, I could see one possible difficulty connected with the valves—I hope to get on to that eventually—but the first thing seemed very definitely to be the removal of possible misunderstandings about vector diagrams as such, applied to circuits using only ordinary circuit components. Looking through a good selection of electrical and radio books, I was surprised to find how few made any serious attempt to explain to the uninitiated how to represent the conditions in a circuit by a vector diagram without risk of ambiguity.

Off I went to a fresh start, then—but again I found the roots of the matter lay deeper. A particular vector diagram shows, shall we say, that at the moment under consideration a certain voltage marked  $V_1$  is positive. What exactly does this mean? Presumably we also have the corresponding circuit diagram, on which  $V_1$  is marked; does that help at all? Suppose Fig. 1 is the part of the diagram concerned. The two arrows show that  $V_1$  exists between two wires, which we shall label  $a$  and  $b$ . The vector diagram, if it is drawn to scale, may tell us how many volts  $V_1$  is. It wouldn't need a vector diagram just to say that. The main object of the vector diagram is to show the directions or phases of the quantities represented by it. But even when it does this, by telling us that  $V_1$  is positive, how much wiser are we? Does it mean that

$a$  is positive compared with  $b$ , or the other way about?

It does seem, then, that it would be a waste of time to talk about vector diagrams before we have cleared up questions like these, concerning the circuit. They are questions of *convention* rather than of fact. The *fact* in our example is a tendency for electrons to move from one wire to the other. Suppose that actually they tended to move from  $a$  to  $b$ . That fact could be conventionally expressed by marking either wire "+" and the other "-." Perhaps the most sensible convention would call  $a$  the positive wire. But the most important thing about a convention is not so much that it should be sensible as that everybody should stick to the same one. If it can be sensible too, so much the better. Conventions are like the rules of a game. If you are playing a game with people who have different rules from yours there is likely to be some unpleasantness, sooner or later. As it happens, the convention that has been universally adopted (unluckily, perhaps) would in this case put the "+" label on  $b$ .

We still have to take care with such a label, not to forget that it refers to  $b$  in relation to  $a$  and does not necessarily hold good with reference to another wire, say  $c$ , towards which  $b$  might be negative. But for the present let us consider  $V_1$  only. It might be as well to attach the "+" label to the  $b$ -ward arrow associated with  $V_1$ , rather than to the wire.

If the positiveness of  $b$  were permanent there would be no need for the vector diagram; + and - signs on the circuit diagram would do. But we are assuming that  $V_1$  is variable and reversible, and we need to know what a positive value for it means. A negative value will then automatically be the opposite.

If one of the wires, say  $a$ , happened to be connected to earth, then the accepted convention that potentials are reckoned relative to earth (unless the contrary is stated) would lead one to guess that a positive  $V_1$

### What is Meant by a Positive Voltage?

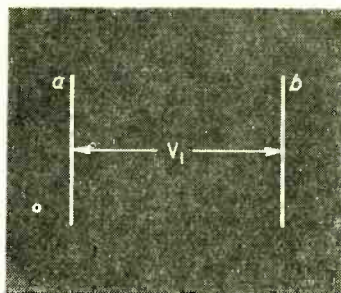

Left: Fig. 1. Example of one common method of labelling a voltage. Unfortunately, knowing whether the voltage is positive or negative does not tell one which ( $a$  or  $b$ ) is positive with respect to the other.

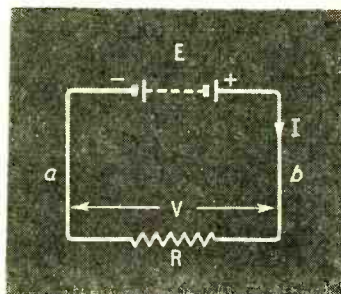

Right: Fig. 2. Considering these additional circuit details may help one to decide on the best way of indicating the polarity of a voltage.



would mean that  $b$  was more positive than  $a$ . But perhaps neither  $a$  nor  $b$  is earthed. What then?

A neat way of indicating the two points and the direction between them is to use the notation " $V_{ab}$ " in place of " $V_1$ ." It is generally agreed that this means "the voltage in the direction  $a$  to  $b$ ," and  $V_{ba}$  is the voltage in the opposite direction. But as regards polarity or sign, it could mean either "the voltage of  $a$  relative to that of  $b$ " or "the voltage change in the direction  $a$ -to- $b$ ." According to the former convention a positive value of  $V_{ab}$  would mean that  $a$  was more positive than  $b$ , and the latter would mean just the opposite.

The few books I have seen that make use of this "double-subscript" notation seem mostly to adopt the first of the two conventions, so that a positive  $V_{ab}$  would mean  $a$  more positive than  $b$ . In other words, it reckons falls of potential as positive.

In Fig. 1 we assumed, if you remember, that  $b$  was more positive than  $a$ . According to the convention just stated this could be expressed by saying either that  $V_{ab}$  was negative, or that  $V_{ba}$  was positive.

Now try applying this to Fig. 2, in which some of the circuit details have been filled in. The voltage originally called  $V_1$  is now seen to be due to an e.m.f., denoted by  $E$ , which tends to drive current ( $I$ ) from its positive to its negative terminal, through the resistance  $R$ , in the clockwise direction indicated by the arrow alongside " $I$ ." (If you prefer to call the direction of the current the same as the direction of electron flow, your arrow will point the opposite way. You may have logic on your side, but you will run the risk of being misunderstood. To the person who knows what he is doing, all conventions are lawful, but—as St. Paul said—not all are expedient). Because the circuit is closed (itself a confusing description, I always think), and there is no stronger opposing e.m.f., current actually must flow as indicated. As a result there is a voltage drop across  $R$ , denoted by  $V$ . The current automatically flows at the strength that makes this voltage exactly equal to the e.m.f. (resistance other than  $R$  being neglected).

If we replace " $V$ " and its rather non-committal pair of arrows by " $V_{ba}$ ," then the fact that  $V_{ba}$  is positive would appropriately be indicated by an arrow pointing from  $b$  to  $a$ , as in Fig. 3. So far so good. But what about  $E$ ? The direction of current flow through the battery is from  $a$  to  $b$ , and according to the assumed convention  $V_{ab}$  (or  $E_{ab}$ , if you prefer) is negative. This follows in another way, if we remember that the convention regarded falls in potential as positive; here we have a rise in potential, which must accordingly be negative.

This idea of regarding  $E$  as negative in the direction from  $a$  to  $b$  seems to follow inevitably from the convention being considered, but it doesn't appeal

to me. The only natural way for me to draw an arrow connected with  $E$  is in the direction in which  $E$  tends to drive current; in this case, clockwise, from  $a$  to  $b$ . If this clashes with the convention, so much the worse for the convention.

The defender of the convention may tell me I have got it wrong—I am mixing up e.m.f.s and p.d.s I ought to know that an e.m.f. drives current from  $+$  to  $-$  through the external circuit and from  $-$  to  $+$  through itself, so of course it must be treated differently.

Well, it is all very nice to be able to discriminate between e.m.f.s and the rest in this way, but (as we saw last month) even the authorities differ on what is and what is not an e.m.f., and busy people have no time to argue it out every time they analyse a circuit. Moreover, it would mean discriminating as regards voltage convention between impedances that are resistances (which have no e.m.f.) and impedances that are reactances (which are sources of e.m.f.).

Reckoning voltages as falls in potential thus gives a result that I for one find unnatural. How about reckoning them as rises? Then  $E$  in Fig. 3 is positive in the direction of current flow, which makes sense of Fig. 4. The double-subscript notation for  $E$ , which would be  $E_{ab}$ , being positive, would have to mean the change in voltage on moving from  $a$  to  $b$ .  $V_{ba}$  (across  $R$ ) would on the same principle be negative. So the appropriate direction for the arrow alongside  $V$  is against the current (Fig. 4). Some people disagree with that, because it makes  $V$  look as if it were an e.m.f. But surely it fits the facts? If you push a table across the floor it moves in the direction in which you exert the "table-motive force," and the table presses against your hands equally in the opposite direction. If the circuit impedance were a reactance, its opposition would be an e.m.f., and there would be no doubt about its being opposite in direction to the applied e.m.f. Although a resistance has no e.m.f. it seems reasonable to treat the voltage drop across it as an opposing voltage.

Provided, therefore, that we can persuade everybody to interpret " $V_{ab}$ " as "the change in potential on moving from  $a$  to  $b$ ," the result is a useful convention that fits in well with other generally accepted or acceptable ideas.

Many people may dislike this system because it makes the voltage across the resistance,  $V_{ba}$ , negative; that is to say, opposite in phase to the current. One is taught that the current through a resistance is in phase with the voltage across it. But "the voltage" here means the voltage driving the current. So the objection can be overcome by reckoning the voltage across the resistance as the one that includes the e.m.f.—the voltage between  $a$  and  $b$  through the source, which is  $V_{ab}$  (or  $E_{ab}$ ), and positive.

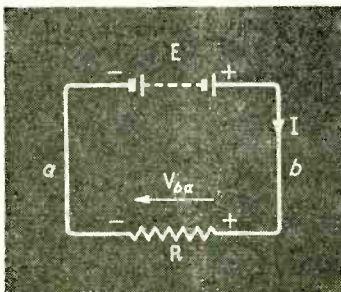

Left: Fig. 3. The double-subscript notation (example,  $V_{ba}$ ) shows the direction in which the voltage is being considered (in this case, from  $b$  to  $a$ ), but an understanding is necessary as to whether a positive value means a rise or a fall in potential. Here it is used to mean a fall, but that leads to awkward results when it is applied to  $E$ .

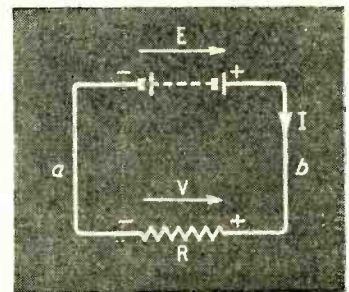

Right: Fig. 4. Here the arrows indicate the directions of rising potential.

There is still one possible cause of confusion to clear up. I have spoken of  $V$  in Fig. 4 as being opposite to  $E$ . "But," you may say, "the arrows are pointing in the *same* direction, from  $a$  to  $b$ !" It is surely a serious matter for one person to say one thing and another person the opposite. Before long they may be calling one another liars. If two people, represented by  $A$  and  $B$  in Fig. 5, were to face one another and discuss a piece of string,  $xy$ , Mr.  $A$  might well declare that  $x$  was the right-hand end of the string, and Mr.  $B$  might be equally sure it was the left-hand end. Mr.  $C$ , asked to adjudicate, might say "Nonsense! It is neither to the right nor left of  $y$ !" The plain man (as he likes to call himself) is so apt to assume that if one statement is true the diametrical opposite must be untrue. But a simple example like Fig. 5 shows the fallacy of this. It all depends on the point of view. I haven't actually heard Messrs.  $A$  and  $B$  in the course of their particular heated argument ("Man! Don't you know your right hand from your left?"), but I have heard heated arguments that were just as futile, because based on the same fallacy.

### Electrical Point of View

Reverting to Fig. 4, anybody who sees  $E$  and  $V$  as being in the same direction should consider Fig. 6, which shows exactly the same circuit. The only difference is that the drawing is laid out a little differently, which you will surely agree can have no effect whatever on the actual voltages in the real circuit. Yet I have actually read an article in which the author confused himself over this very thing. It is the point of view again. The way Fig. 4 is drawn tends to suggest a parallel circuit, whereas Fig. 6 looks more like a series circuit. Either series or parallel (or both) may be right, depending on circumstances and the way one is considering the circuit. The particular way the circuit diagram is arranged does not necessarily decide the matter, though admittedly diagram layout is a useful method of suggesting the point of view the drawer intends.

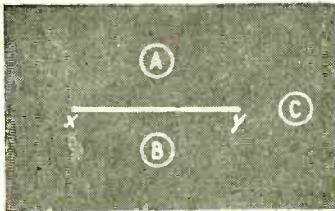

Fig. 5. Three people, situated respectively at  $A$ ,  $B$ , and  $C$ , would have different views as to whether  $x$  was to the right or left of  $y$ .

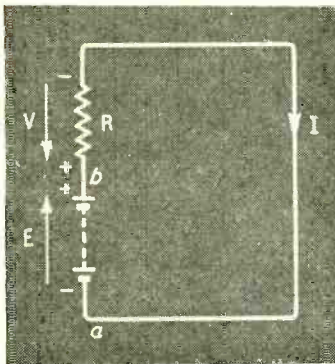

Fig. 6. This circuit is identical with that in Fig. 4; only the drawing is different.

Sometimes it is convenient to reckon voltages with reference to a particular point in the circuit (usually an earthed point); at other times they are reckoned round the circuit.

This is where a sound system of notation is necessary. As far as voltages are concerned, it should indicate clearly the two points between which the voltage exists, and the direction in which it is being reckoned between those points. This does not necessarily mean the direction in which it is actually operating.  $E$  in Fig. 4 is operating from  $a$  to  $b$ , if one judges by the fact that it is driving or tending to drive current in that direction. But we can reckon it in either direction, as  $E_{ab}$  or  $E_{ba}$ . In this case  $E_{ba}$  would be negative.

The double-arrow notation used in Figs. 1 and 2 is very good for showing the terminal points of the voltage, but fails to distinguish one direction from the other. The single-arrow system (Figs. 4 and 6) certainly shows the direction but leaves one to guess the points. Moreover I suspect that it is commonly used to show the direction in which the voltage acts, so using it to show the direction of reckoning may cause confusion. The double-subscript notation  $-V_{ab}$  and so forth—states quite definitely both of the points and a direction between them. I think it is universally agreed that the direction is from the first subscript letter to the second.

Whichever point of view one takes, this notation fits in with familiar electrical axioms. If you consider the voltage of one point relative to another, then you have the fact that the voltage between two points is the same regardless of the path you take between them. The voltage from  $a$  to  $b$  is called  $V_{ab}$  and, in Fig. 4 for example, is inevitably the same whether one reckons clockwise or anticlockwise. If you take the rotational point of view, then the principle is that no point can be at two different voltages, so if you go round any circuit the sum of the voltages must be zero. Round Fig. 4 we have  $V_{ab} + V_{ba}$ , and as  $V_{ba}$  means  $-V_{ab}$ , there can be no doubt about the total being zero.

It is a matter of convenience which way round one reckons a closed circuit. Some people tend to go clockwise round the diagram. But it must be remembered it may mean either way round the actual circuit, depending on the particular way the circuit diagram is drawn. Although Fig. 7 represents exactly the same circuit as Figs. 6 and 4, taking it clockwise would reverse all the signs. They would still be correct relative to one another, of course. Another custom is to adopt the direction in which the current is flowing. If that is unknown it doesn't matter; a "wrong" guess will merely result in a negative value for the current, which just means that it is flowing the other way. The important thing is to mark the assumed direction of current on the diagram.

So far, our example has for the sake of simplicity been a d.c. circuit, on which  $+$  and  $-$  signs have been marked, taking care that they are clearly arranged in pairs so as to show which point is negative with respect to each positive. Although with a.c. the signs are periodically reversing, it is allowable and sometimes convenient to mark them on a circuit diagram, on the clear understanding that they refer, say, to the first half of each cycle. During the second half all will be reversed, so relative to one another will be the same. This rather unorthodox practice is useful for quickly working out the relative signal polarities in a multi-stage amplifier, as when finding



whether a proposed connection will give negative or positive feedback; but of course one has to take care to keep the a.c. signs quite distinct from the various d.c. polarities. Except for very rough work it is far better to use vectors, because they cannot be confused with the d.c. symbols, and (much more important) they are not restricted to only two phase relationships— $0^\circ$  and  $180^\circ$ .

So next time we shall deal with vector diagrams. Meanwhile Fig. 8 is an example for giving some practice in the use of the notations we have just been considering. Try working out the values of all the voltages, before looking at the answers in the table. Because the circuit is linear (i.e., subject throughout to Ohm's Law) the d.c. and a.c. can each be calculated separately just as if the other didn't exist.

Here is a summary of the notations:

(1) A voltage between two points can be identified on a circuit diagram by a numbered  $V$  with a pair of arrows marking the points, as in Fig. 1.

(2) If the points are labelled (say  $a$ ,  $b$ , etc.) an alternative to (1) is the double-subscript notation ( $V_{ab}$ , etc.) which has the advantages

(i) that it is not necessary to mark the voltage symbols and arrows on the circuit diagram, and

(ii) that the voltages in the opposite directions are distinguishable as  $V_{ba}$ , etc., thus enabling one to keep the *relative* polarities throughout the circuit right.

(3) A further advantage follows if it is agreed whether the reckoning is in falls or rises of potential. If in falls, then a positive  $V_{ab}$  means that  $a$  is more positive than  $b$ ; if in rises, it means  $b$  is more positive than  $a$ .

(4) Compared with (3),  $+$  and  $-$  signs on the circuit diagram may be misleading, because a single point can be both positive and negative, depending on which other point it is being related to. Also their usefulness is very limited in dealing with a.c.

(5) Single directional arrows are sometimes used to indicate the positive direction of e.m.f. or of electric field. But since these are usually opposite there is risk of confusion through doubt as to which is meant.

Fig. 7. Still another version of Figs. 4 and 6, in which the rotation is reversed.

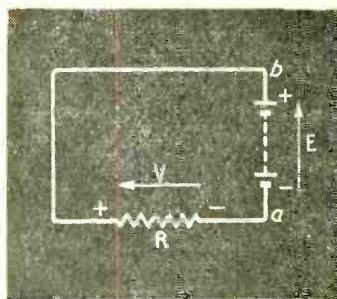

Below: Fig. 8. A circuit for practice in working out, using the double-subscript notation. The a.c. e.m.f. may be taken as positive anti-clockwise.

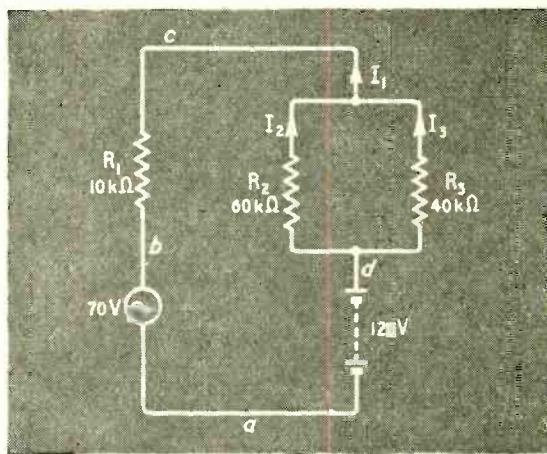

(6) Whatever method is adopted, in order to give any meaning to polarity (or sign) it is necessary to specify

(i) the direction of reckoning, and

(ii) whether reckoning in rises or falls of potential.

If only relative polarities are required, as usually in a.c. circuits, the direction adopted does not matter so long as the same one is used throughout the reckoning.

The following table is the full working-out of Fig. 8 in four different ways, from which you can

	Clockwise				Anticlockwise				How derived	
	Rise		Fall		Rise		Fall			
	D.C.	A.C.	D.C.	A.C.	D.C.	A.C.	D.C.	A.C.		
$V_{ab}$	0	-70.0	0	70.0	$V_{ba}$	0	70.0	0	-70.0	Given a.c. e.m.f. Given d.c. e.m.f. $R_{23} = 24$ , so total resistance $R_1 + R_{23} = 34$ $= -I_1 R_1$ $= -I_1 R_{23}$ $V_{bd} = V_{bc} + V_{cd}$ $V_{ab} = V_{ac} + V_{cb}$ (either = - e.m.f.) $= -V_{cd}/R_2$ or $-V_{ac}/R_2$ } To- $= -V_{cd}/R_3$ get- or $-V_{ac}/R_3$ ter $= I_1$ $V_{ac} = V_{ab} + V_{bc}$ $V_{ca} = V_{cb} + V_{ba}$
$V_{da}$	-120.0	0	120.0	0	$V_{ad}$	120.0	0	-120.0	0	
$I_1$	-3.53	-2.06	3.53	2.06	$I_1$	3.53	2.06	-3.53	-2.06	
$V_{bc}$	35.3	20.6	-35.3	-20.6	$V_{cb}$	-35.3	-20.6	35.3	20.6	
$V_{cd}$	86.7	49.4	-84.7	-49.4	$V_{dc}$	-84.7	-49.4	84.7	49.4	
$V_{bd}$	120.0	70.0	-120.0	-70.0	$V_{db}$	-120.0	-70.0	120.0	70.0	
$I_2$	-1.41	-0.82	1.41	0.82	$I_2$	1.41	0.82	-1.41	-0.82	
$I_3$	-2.12	-1.24	2.12	1.24	$I_3$	2.12	1.24	-2.12	-1.24	
$V_{ac}$	35.3	-49.4	-35.3	49.4	$V_{ca}$	-35.3	49.4	35.3	-49.4	

Note that the a.c. and d.c. voltages between  $a$  and  $c$  are opposite in sign.

take your choice. Personally I would scrap the "fall" methods as a general principle; and in this particular case would choose the anti-clockwise rotation because both the e.m.f.s are positive that way. Note that the figures are the same in all four reckonings; only the signs differ. And the "clockwise rise" signs are the same as for "anticlockwise fall," and opposite to those of the other two. The rotation selected is indicated by the double-subscript notation: " $V_{ab}$ " implies the direction a-to-b, and  $V_{ba}$  the opposite. Remember too that in the "rise" columns a positive  $V_{ab}$  means  $b$  more positive than  $a$ , and vice versa in the "fall" columns. A.c. is given in r.m.s. values; resistances are in

$k\Omega$ , and currents in mA.  $R_{23}$  means the resistance of  $R_2$  and  $R_3$  in parallel ( $=R_2R_3/(R_2+R_3)$ ). The current is in every case assumed to flow in the same direction as the e.m.f.; that is why voltage drops are *minus* current  $\times$  resistance. To avoid this minus sign some people reckon rises and falls separately, and their totals should then be equal; but by reckoning all the voltages as rises (or all as falls) one has the useful check that the total round the whole circuit must always be zero.

Unfortunately the convenient double-subscript notation cannot be applied to currents: both  $I_2$  and  $I_3$  flow from  $d$  to  $c$ . So some other method of identification has to be used.

## SHORT-WAVE CONDITIONS

### November in Retrospect : Forecast for January

By T. W. BENNINGTON (Engineering Division, B.B.C.)

**D**URING the past three months sunspot activity has been decreasing more rapidly than would have been expected earlier in the year. The result has been that, since September, the maximum usable frequencies for long-distance transmission have been considerably lower than those predicted. The autumnal increase in day-time working frequency has, therefore, been much smaller than was expected, and the higher short-wave

frequencies—like the 28-Mc/s band—have never become regularly usable. How long this depression in usable frequencies will last it is impossible to say, but it is unlikely that 28 Mc/s will again become regularly usable over east-west paths during the present sunspot cycle.

The average maximum usable frequencies for these latitudes during November were somewhat higher by day, and slightly lower by night, than during the previous month, which variation was in accordance with the normal seasonal trend.

Day-time working frequencies were moderately high, but lower than had been expected, whilst those for night-time were relatively low. The 28-Mc/s band was usable on a few occasions, but never for many days in succession, and the highest day-time frequencies were more often of the order of 22 Mc/s. At night working frequencies were generally lower than 7 Mc/s.

Unexpectedly, Sporadic E was more prevalent than during the previous month, though not often of sufficient density to sustain propagation on very high frequencies.

Sunspot activity was, on the average, considerably lower than during the previous month.

There was a considerable amount of ionospheric storminess, and during the periods 1st-5th, 10th-15th and 24th-30th reception was adversely affected by such disturbances. Only one Dellinger fadeout was reported—at 1135 on 28th.

**Forecast.**—Both day-time and night-time m.u.f.s during January should remain about the same as during December.

Long-distance working frequencies should thus be moderately high by day and definitely low by night. The highest regularly usable frequencies by day should be of the order of 22-24 Mc/s, whilst at night-time they will probably be as low as 6 Mc/s over most circuits. Medium-high frequencies—like 15 Mc/s—will be the most useful for long periods during the day-time.

Sporadic E capable of sustaining propagation on very high frequencies is unlikely to be very prevalent. Ionospheric storms, whilst not usually particularly prevalent during January, are likely to be troublesome when they do occur, especially at night.

The curves on the left indicate the highest frequencies likely to be usable over four long-distance circuits during the month.

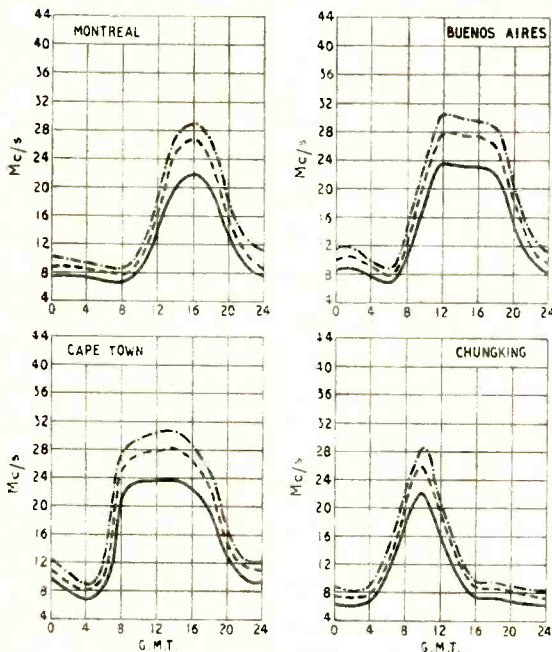

— FREQUENCY BELOW WHICH COMMUNICATION SHOULD BE POSSIBLE ON ALL UNDISTURBED DAYS  
 - - - PREDICTED AVERAGE MAXIMUM USABLE FREQUENCY  
 - · - FREQUENCY BELOW WHICH COMMUNICATION SHOULD BE POSSIBLE FOR 25% OF THE TOTAL TIME





Close-up of booster unit mounted close to the line-scan output valve.

WITH the present trend towards brighter pictures, aluminium-backed screens, and neutral light filters (i.e., "black screen" receivers), higher e.h.t. voltages have become general practice today. There must be many owners of somewhat older television receivers, whether commercially-built or home-constructed, who would like to improve their picture by increasing the e.h.t. voltage and substituting a modern tube designed for a higher anode voltage. In making such an improvement it is very desirable, in the interests of economy, to retain the existing e.h.t. supply (of whatever type), but to augment its output by about 30 per cent to 50 per cent while still retaining good voltage regulation.

The circuit described here allows this to be done in any conventional receiver, whatever form of e.h.t. supply it now employs, at very reasonable cost and without disturbing or overstressing the existing e.h.t. components in any way.

### Form of Circuit

In any magnetically-deflected receiver, high-voltage line-frequency pulses are available at the anode of the line-scan output pentode. These pulses usually reach an amplitude of about 2 to 2.5 kV above earth, so that they are of just the right order of magnitude for providing the required boost to the e.h.t. supply, but at first sight it appears a little difficult to persuade them to add on to the existing (say) 5 kV supply without using a double-wound transformer or raising the entire line-scan generator to an uncomfortable potential above earth! Fortunately this can be overcome by making use of multiplier technique, and a suggested circuit is shown in Fig 1.\*

The operation is as follows: between line fly-back

# Flyback E.H.T. Booster

## Increasing Tube Voltage in Television Sets

By A. H. B. WALKER, B.Sc. (Hons.), A.M.I.E.E.

(Research Laboratory, Westinghouse Brake & Signal Co., Ltd)

pulses C, charges up to the original e.h.t. voltage through R, and point A therefore reaches (say) 5 kV above earth. When the line fly-back pulse occurs, the valve anode potential increases by (say) 2.5 kV and, since the charge in C, cannot change sufficiently rapidly, point A is also carried up an additional 2.5 kV, reaching a total of 7.5 kV. At this instant MR conducts, charging C<sub>2</sub> to 2.5 kV (since C remains steadily charged at 5 kV). No change in the operating conditions of the original e.h.t. unit is therefore caused, all the "boost" voltage being developed across C<sub>2</sub>. Any potentiometer chain should be left connected to the original e.h.t. supply output.

If the receiver already derives its e.h.t. supply from the line fly-back the most obvious way of increasing the output is to convert the rectifier from a half-wave circuit to a voltage-doubler. This can easily be arranged but it suffers from two practical disadvantages. The first is that the e.h.t. produced will usually be of the order of 12 kV which is too high

Fig. 1. Fly-back booster applied to an existing mains driven e.h.t. supply unit. C<sub>1</sub> = 0.001μF (working voltage equal to original e.h.t. voltage); C<sub>2</sub> = 0.001μF. 3kV working; R = 2 MΩ, 1 watt; MR = Westinghouse 36EHT40.

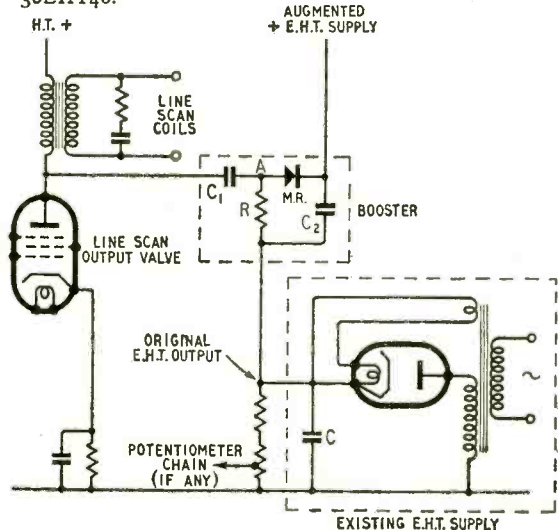

\* Virtually the same circuit has been suggested independently by L. J. Hills, who described it in a letter in the November 1950, *Wireless World*, p. 412 [Ed.]

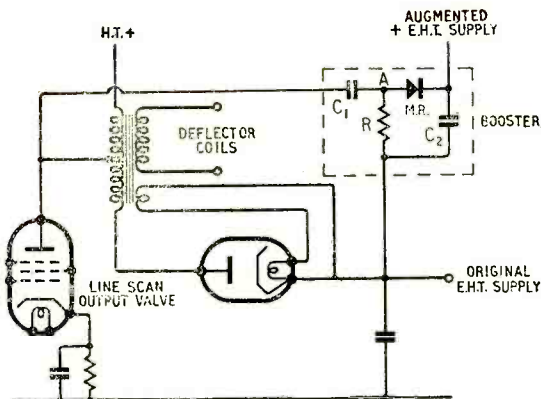

Fig. 2. The booster of Fig. 1 applied to a conventional flyback e.h.t. supply. When the transformer ratio is about 2:1 this produces not a doubler but a "1½-er." The booster components are as in Fig. 1.

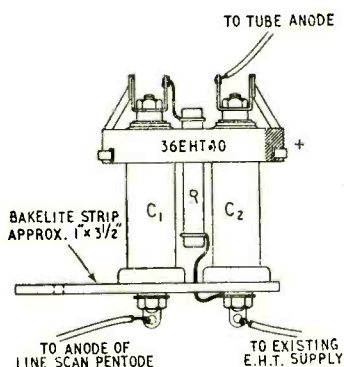

Fig. 3. Constructional details of booster.

to enable the tube to be scanned without redesign of the scanning circuit; and the second difficulty is that the additional current burden on the line-scan transformer, when reflected into the primary, results in somewhat poor regulation. To produce the required increase of, say, 40 per cent in e.h.t. voltage it seems that the most useful circuit would be something giving a greater output than a half-wave rectifier, but less than a voltage doubler, in fact a "one-and-a-half-er." This result can be achieved with good regulation by using the pulse at the anode to supply a boost rectifier, and adding the output of this to the original e.h.t. derived from the transformer overwinding. Where the transformer ratio is 2:1 this does, in fact, result in about 40 per cent increase in output. The arrangement is shown in Fig. 2, and is basically similar to Fig. 1.

Since the additional rectifier is fed directly from the valve anode through  $C_1$ , it adds no burden to the e.h.t. auto-transformer, and its self-capacitance is therefore only added directly to the anode circuit instead of being multiplied by  $n^2$  (where  $n$  is the ratio of the auto-transformer winding). By returning capacitor  $C_2$  to the position shown and not to earth, it need only be rated for the amount of the increase in e.h.t. voltage, and not the full new value.

The form of construction adopted depends mainly on the type of capacitors used. Although not strictly essential it is more convenient to use two identical capacitors, and a suggested layout is shown in Fig. 3. This has the merit of being small and very light so that it is easily mounted in the required position.

The booster is best connected in series in the existing e.h.t. lead to the tube anode, a single new lead being taken directly to the top cap (anode) of the

line-scan pentode. In most receivers this lead need not exceed a few inches in length (see photograph), but if the line-scan pentode is some distance from the present e.h.t. lead it is preferable to extend the latter and mount the booster near to the valve so that the pulse-feed lead is kept as short as possible.

The components required are only:—One 2 MΩ resistor of 1 W rating, two 0.001 μF, 6 kV, capacitors (such as, T.C.C. type CP55QO) and one metal rectifier of 2.9 kV rating (Westinghouse type 36EHT40).

After increasing the e.h.t. in an existing receiver it is, of course, necessary to increase the output of the line- and frame-scanning amplifiers slightly, and in most cases there will be sufficient output margin to deal with the increase in e.h.t. which this booster will produce. If  $V_1$  is the original e.h.t. voltage, and  $V_2$  the augmented voltage, then the scanning-current output must be increased in the ratio of  $\sqrt{V_2/V_1}$  to fill the screen again, and this adjustment can usually be made by the height and width controls. If  $V_2/V_1 = 1.4$ , then the necessary increase in scanning output current is approximately 18 per cent.

The actual increase in e.h.t. obtained naturally depends entirely on the amplitude of the flyback pulse, and this varies considerably between receivers. The rectifier referred to earlier is suitable for any pulse up to 2.9 kV peak, but if the pulse is known to be much less than this a smaller rectifier could be used and the boost obtained would, of course, be smaller. As an example of results the following figures were taken on a receiver using a conventional fly-back e.h.t. system operated from a driven (i.e., not self-oscillating) output pentode. The 'augmented e.h.t.' readings were recorded after the line-scan output had been increased, so that the screen was again filled.

Mean Beam Current	Original E.H.T. Voltage	Augmented E.H.T. Voltage
10 μA	6.0 kV	8.75 kV
50 μA	5.75 kV	8.45 kV
100 μA	5.5 kV	8.05 kV
Overall regulation,	8.3%	8.0%

The interesting point which is brought out by these figures is that the regulation has not been impaired by the additional circuit, but has actually been slightly improved. This result is partly due to the helpful self-regulating action of the Type 36 EHT metal rectifier. This use of the 'limiting' action of suitable metal rectifiers to improve the regulation of fly-back e.h.t. circuits was proposed by the present writer,<sup>1</sup> and has since been further discussed by Cocking.<sup>2</sup>

<sup>1</sup> "Metal Rectifier Voltage Multipliers." A. H. B. Walker, *Journal Tele. Soc.*, Vol. 5, No. 11.

<sup>2</sup> "Fly-back E.H.T." W. T. Cocking, *Wireless World*, September 1950.

## HEAVISIDE CENTENARY VOLUME

THIS book is a symposium of I.E.E. papers read at the Oliver Heaviside centenary celebrations in May last year. Although it contains little of direct interest to radio engineers, one suspects that if the world of radio had not thrust Heaviside into undeniable fame as prophet of the ionosphere, the main body of his valuable work would have remained unused and there would have been no book. However, the mathematically minded will doubtless find great interest in the papers on Heaviside's Operational Calculus, his contributions to electromagnetic theory and his hitherto unpublished notes. Copies can be obtained from the I.E.E. at Savoy Place, London, W.C.2, price 10s or 4s to members, post free.



# Your Loudspeaker

*How Many Watts Should it Need and Should the Amplifier be "Flat"?*

By THOMAS RODDAM

**A**N article which appeared in the February 1950 issue of *Wireless World* provoked a letter from Mr. Thomasson, who said that a mean output of 50 mW involved a peak output of 5 watts. I was rather suspicious of this figure, so I have been examining the problem more closely. First of all, there are two references which serve as a useful starting point: one, a paper by Divoire (*L'Onde Electrique*, January 1936), the second by Pawley (*Wireless Engineer*, January 1937).

Divoire measured the instantaneous level of "programme material" and showed that the level, in decibels, followed the normal probability curve. From the figures given I deduce that for chamber music, the level must be 20 db above average for 1 per cent of the time. For 1 per cent of the time, too, it will be 20 db below average. Piano music gives a wider dynamic range, about 50 db instead of 40 db.

This certainly seems to confirm Mr. Thomasson's figure of 5 watts. The only conclusion we can reach is that my figure of 50 mW mean level was wrong, because the output stage, rated at 2 watts for 1 per cent distortion, will produce quite a lot more noise without unpleasantness. What sort of level is really needed for home listening?

To begin with, let us assume that we want the news to be read at ordinary conversational level. This means that the sound intensity should be about 70-75 db above  $10^{-10}$  microwatt/cm<sup>2</sup>. This is only 35-40 db above the miscellaneous household noises, so that the lowest sound level will drop down fairly near to noise.

The Western Electric Company has published some information on the power required to produce a given sound level in rooms of various sizes. A typical small sitting-room is about 12ft. × 15ft. × 10ft. and thus has a volume of 1800 cubic feet. To produce a level of 80 db above  $10^{-10}$   $\mu$ W/cm<sup>2</sup>, using a not very efficient cone loudspeaker, we need, according to the Western Electric Company, an input power of about 200 milliwatts (+ 23 db/1mW). As we saw above, + 70 db/ $10^{-10}$   $\mu$ W/cm<sup>2</sup> represents a good mean level, and this corresponds to + 90 db/ $10^{-10}$   $\mu$ W/cm<sup>2</sup> peak level when the signal has a range of 40 db. The peak power into the loudspeaker must therefore be 10 db higher than the 200 milliwatts mentioned above, or 2 watts. The amplifier is therefore required to deliver a power of 2 watts to give ordinary conversational level.

This 2 watts, however, is a peak power. The amplifier will be tested with a sinusoidal signal, which gives 2 watts peak power when the root-mean-square power, the value we usually measure, is 1 watt. From this it is clear that a 1 watt amplifier will just suffice to give us a suitable level with a dynamic range of 40 decibels.

When we turn to the reproduction of music the question of level becomes rather difficult. My own personal view is that mechanical reproduction, and that goes for radio, too, should only be used for chamber music. Mr. Rudo S. Globus, writing in *Audio Engineering* (February 1950), expresses a different view: he holds that symphony music is better heard from records than in the concert hall, while chamber music and jazz demand a personal contact. But symphony music demands a range of somewhere between 60 db and 100 db. For broadcasting purposes, I suspect that the range is always kept down to 60 db, in which case the peak power, assuming that we keep the mean level constant, rises to 10 watts.

## Peak Limitation

The reader will have already noted that our design criterion was the level which is exceeded only 1 per cent of the time. He may ask whether we should not push our peak power up to 100 watts, so that distortion occurs only 0.1 per cent of the time. The answer is simple. Already, earlier in the chain between microphone and loudspeaker, the peaks have been chopped off. A 60-db range for symphony music means that the mean modulation can only be 3 per cent, a pretty low sideband power. The transmitter limits quite firmly at 100 per cent modulation, and if we are worried about distortion the limit is about 20 per cent. Those peaks just don't get out.

Looking back, we see that the ordinary home, for really good reproduction of symphony music, needs a 10 watt amplifier, but that for speech and chamber music we can get along with only 1 watt. We can also see that my quiet background music is at a mean level of only about 5 mW: it does not seem very much.

The other thing, or one of the other things, about which I get into trouble, is the question of the transient response of loudspeakers. Some writers on this subject always seem to be rather starry-eyed about quality, because they never allow for the imperfections of the earlier parts of the system. Any reader who wants a shot of realism should look at the distortion figures quoted for transmitters and for disc recording.

However, I do not want to talk about non-linear distortion, but about transient response. A recent article by Moir (*Wireless World*, May 1950) described what happened when the driving impedance of a loudspeaker amplifier was varied, and showed how reduced impedance affected the over-swing. Unfortunately, there is more in the circuit than a loudspeaker.

At this point I must digress. At various periods of

my life I have designed amplifiers for broadcasting administrations. They always ask for a flat frequency response and for low noise. This means that the amplifiers have to be designed to cut off fairly sharply above the permitted top frequency, to keep the noise bandwidth down. There will probably be at least half a dozen such amplifiers in tandem between microphone and transmitter input.

Recently I adopted the policy of using square-wave testing for adjusting a response trimming capacitor in the feedback circuit. The information obtained made it easy to adjust the response to be flat within  $\pm 0.5$  db up to 15,000 c/s, and remember, there is always an input transformer. But to achieve the desired response, it was necessary to provide some overshoot. An analysis of the problem in some detail has recently been published by J. E. Flood (*Wireless Engineer*, July 1950), and two of Mr. Flood's diagrams are reproduced in Figs. 1 and 2. Although these curves are on the wrong scale for audio-frequency working, the effect is merely one of scale. It will be seen that by rounding off the response

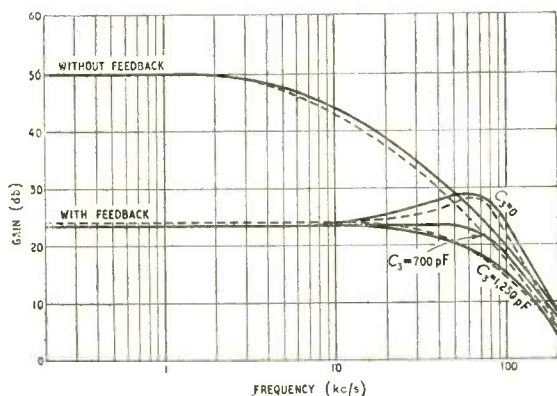

Above : Fig. 1.—Measured (solid line) and calculated (dashed line) responses for a two-stage resistance coupled amplifier with 26 db feedback.  $C_3$  is in the feedback circuit. Below : Fig. 2.—Response to a 35-usec pulse of the amplifier with response curves shown in Fig. 1.

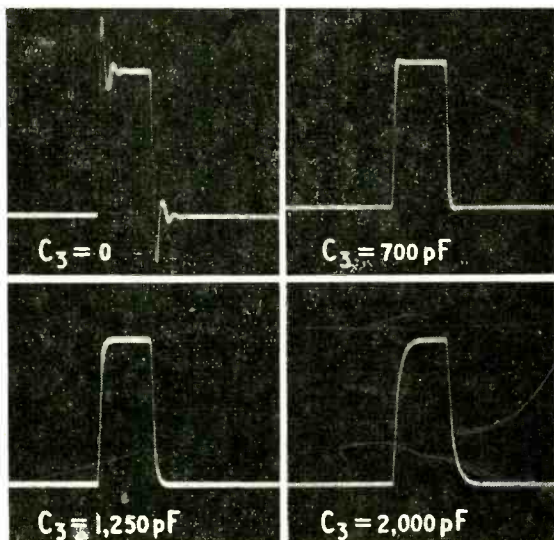

with a capacitor in the feedback circuit ( $C_3$  in Fig. 14 of the article referred to), the overshoot can be reduced, and the amplifier can become over-damped. The curve and pulse response for  $C_3 = 1250$  pF represent the critically damped condition, and it will be noted that the frequency response starts to droop relatively early. In an amplifier using transformers the effect is even more pronounced owing to the more rapid cut-off produced by the transformers. A really flat amplifier with input and output amplifiers will have a transient response rather like that shown for  $C_3 = 0$ .

The reverse is also true. If we want a transient response like that shown for  $C_3 = 1250$  pF we must allow the response to droop pretty early. There is thus a conflict between the "flat response" and the "no overshoot" response. Unless the amplifier and loudspeaker are flat up to very high frequencies, when we shall no longer care.

How is this conflict to be resolved? Let us consider why the response has an overshoot. The square wave contains components of frequencies right up to infinity, in theory, and up to about 1 Mc/s with most square-wave generators. The "error" signal shown in Fig. 3(c) is made up of all the frequency components which do not pass through the amplifier, and we can say that a false signal, made up of all those components with reversed sign, has been generated. But these components are above our top cut-off, and that means that the response can go up to a reasonably high frequency and we shall still not hear the error-signal. So this set of transient responses does not matter: indeed, it shows that we have got a fairly flat response.

The reader may question whether this applies also to loudspeaker resonances, and many suspect that these will produce overshoots which somehow avoid this dependence on frequency response. The answer is that frequency response and transient response are inextricably mixed up, and a flat frequency response means that the only transients can be at the cut-off frequencies. So flatness pays.

This is only one aspect of a problem which can be approached from several stand-points. Coupled with one method used by Olson for loudspeaker design—the network approach—it can, I think, prove helpful.

Fig. 3.—The square wave with overshoot (a) can be regarded as being made up of a square wave (b) shown as the leading edge step, together with an error signal (c).

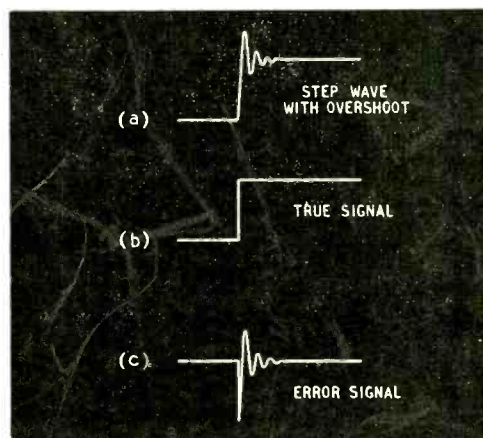



# Unusual Ladder Filter

## Applications in Audio and Radio Circuits

By F. G. G. DAVEY, M.A., A.M.I.E.E.

(E.M.G. Handmade Gramophones)

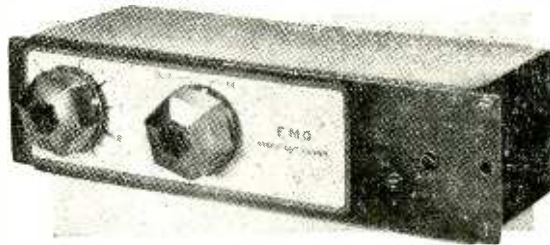

E.M.G. step-cut variable filter for connection between output transformer and loudspeaker.

THE possibilities of the simple ladder filter are by no means exhausted by the classical filter theory. In one sense, any stray collection of reactive components, connected together as a simple ladder, is a filter. It will only lack value for design purposes because the calculation of its performance is laborious and needs to be repeated in full for every fresh case. To be generally useful, a filter must have some regularity in its design which simplifies the formulae and makes them readily applicable to a large variety of particular cases.

Broadly speaking, in the classical filter theory this regularity is that the characteristic impedance of each section is the same. In the filter which is the subject of this article a different regularity has been chosen, which is that the impedances looking forward and backward from the central element bear a constant ratio to each other with change of frequency and maintain equal phase-angles. This condition leads to quite general formulae which are sufficiently simple for use. It also leads to a filter with some rather unusual properties which are of value in radio design.

In order to fulfil the chosen condition, it is clear that there must be an odd number of reactive elements (i.e., series and shunt arms). It is also clear that all those elements coming before the central element must be proportioned to the input terminal resistance, while all those following the central element must be similarly proportioned to the output terminal resistance. For the sake of a further simplification of the formulae, the central element itself is expressed in terms of the two terminal resistances together—in series if it is a series element and in parallel if it is a shunt element.

Let us take an example. Suppose a low-pass filter is required consisting of five reactive elements working between an input resistance  $a$  and an output resistance  $b$ , (see Fig. 1). The nominal cut-off frequency will be called  $f_c$ . The first inductor has a reactance  $2\pi f_c L_1 = ka$ , where  $k$  is some constant to be determined. The

next element, the shunt condenser, must then have a reactance  $\frac{1}{2\pi f_c C_1} = ka$ . The second inductor,  $L_2$ , being the central element, has a reactance  $2\pi f_c L_2 = m(a+b)$ , since it is a series arm.  $m$  is another constant to be chosen. The last two elements will be fixed in the same way as the first two, but using  $b$  in the formula instead of  $a$ .

First to be considered is the filter obtained by maintaining  $m = k$ . It is found that varying  $k$  alters the shape of the response curve given by the filter. Some typical curves are given in Fig. 2 for a five-element filter, and in Fig. 3 for a three-element filter.

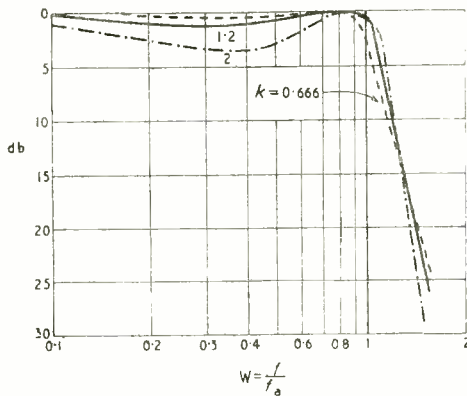

Fig. 2. Response of five-element low-pass filter with varying  $k$ .

Fig. 3. Response of three-element low-pass filter with varying  $k$ .

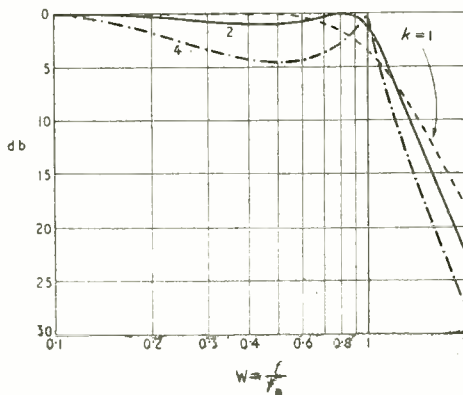
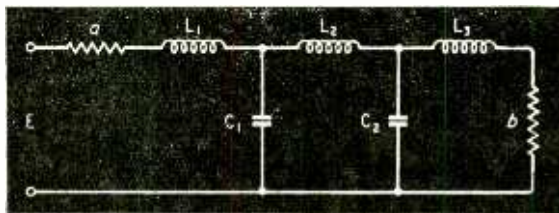

Fig. 1. Five-element mid-series filter.



It will be seen that the higher values of  $k$  give steeper cut-off slopes, but that this is offset by an increasing amount of "sag" in the pass band. Now, in radio work filters are often required to give as level a response as possible in the pass band, with as steep a fall as possible outside it. If a response not more than 1 db down anywhere in the pass band is considered good enough, then this will be given by making  $k = 1.2$  for the five-element filter and  $k = 2$  for the three-element filter. If the actual cut-off frequency  $f_a$  is taken to be the point where the response is 1 db down for the last time, it will be found that this occurs, for the five-element filter, at the frequency  $f_a = 1.3f_c$ . In terms of the actual cut-off, then, the design formulae for this performance become :

$$2\pi f_a L_1 = 1.56a$$

$$2\pi f_a L_2 = 1.56(a + b)$$

$$2\pi f_a L_3 = 1.56b$$

$$\frac{1}{2\pi f_a C_1} = 0.923a$$

$$\frac{1}{2\pi f_a C_2} = 0.923b$$

the central element would have been a shunt arm. An identical performance would then have been given by putting  $k = \frac{1}{1.2}$ . In this case, therefore, the design formulae would become :

$$\frac{1}{2\pi f_a C_1} = 0.642a$$

$$\frac{1}{2\pi f_a C_2} = 0.642 \frac{ab}{a+b}$$

$$\frac{1}{2\pi f_a C_3} = 0.642b$$

$$2\pi f_a L_1 = 1.084a$$

$$2\pi f_a L_2 = 1.084b$$

Fig. 4 shows the response curve for a five-element filter designed to these formulae as compared with a simple filter with the same number of elements designed to the conventional formulae. It will be seen that, apart from the 1 db dip in the pass band which we have allowed ourselves, nothing has been lost in performance—indeed there is an appreciable gain in sharpness of cut-off.

Exactly similar performance curves can, of course, be obtained for high-pass filters, and bandpass filters can also be produced on similar lines.

If a mid-shunt filter had been considered (three shunt condensers separated by two series inductors)

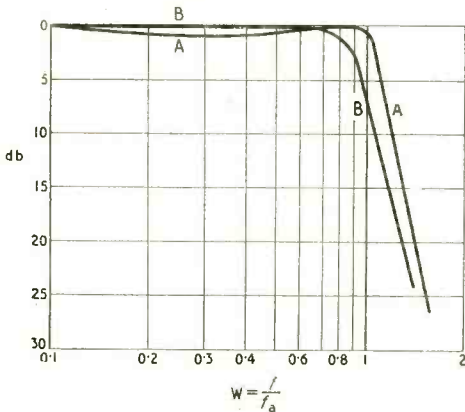

Fig. 4. A, five-element filter with  $k = 1.2$  ; B, five-element conventional filter.

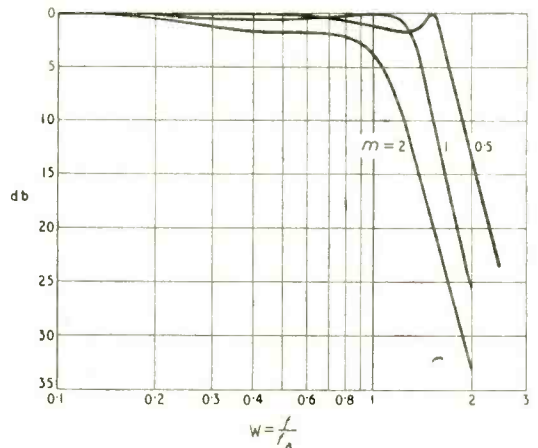

Fig. 6. Response of five-element low-pass filter with varying  $m$ .  $k = 1$  throughout.

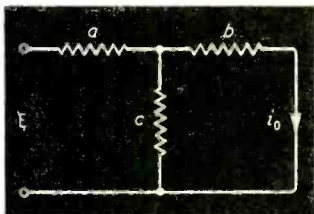
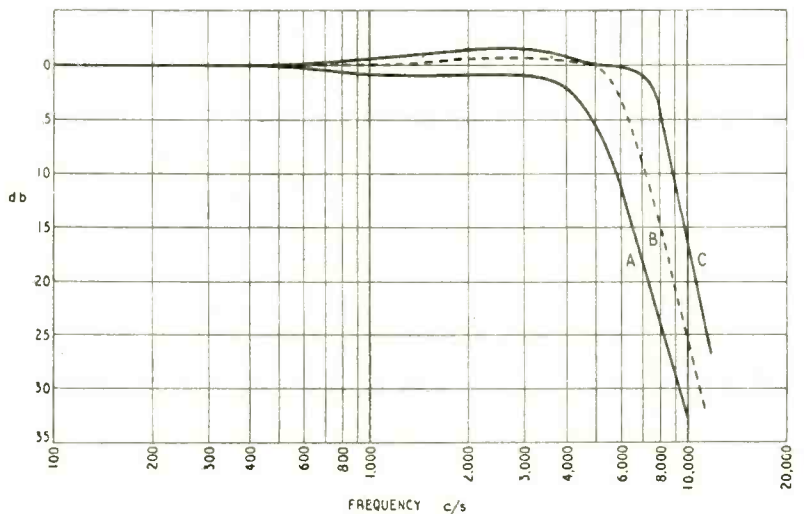

Fig. 5. The output current  $i_o$  is governed more strongly by the central element  $c$  than by either of the others.

Right: Fig. 7. Response curve of infinitely variable filter inserted between transformer and Wharfedale "Golden" speaker. Insertion loss 0.75db. A, minimum setting; B, approximately half way, C, maximum setting.





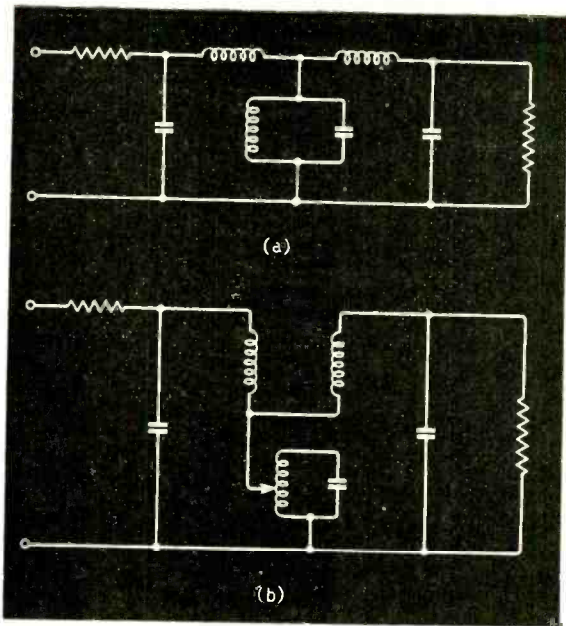

Fig. 8. Bandpass five-element filter (a), redrawn (b) as a three-circuit coupler.

We come now to the property which renders these filters somewhat unusual. It can be shown (see Appendix) that the cut-off frequency is much more strongly controlled by the value of the central element than by any other single element; that is why, at the start, the central element was given a different coefficient  $m$  from the other elements. This can be roughly illustrated by taking the simplest possible case, shown in Fig. 5. Here, the current through the

output resistance  $b$  is  $i_0 = \frac{cE}{ab + bc + ca}$ . Obviously,

changes in the value of  $c$  are going to affect  $i_0$  much more strongly than similar changes in  $a$  or  $b$ . This property remains true even though  $a$  and  $b$  become more complex networks, so long as the condition defining these filters is retained.

Fig. 6 shows some typical curves that result from varying  $m$  while retaining  $k$  constant. In this case there is a variation in the pass band of 2 db, while the cut-off at 2 db down has been varied in frequency by about an octave. Better results would have been obtained by using a rather higher  $k$ , but these curves show the kind of limits to variation of  $m$  that must be expected.

The five-element filter has been used in practice as a variable high-note filter for loud-speakers†. In this application the terminal resistances are not constant but vary quite markedly with frequency. It happens, however, that the variations are generally such as to improve the filter performance. Fig. 7 shows the measured results.

Another rather useful property shows up in this practical case. It follows, from the fact that the central element exercises a more than proportionate control on the performance, that the other components exercise less. Hence they need not be very accurately matched to their theoretical value. Now the filter of Fig. 7 is of the five-element mid-series type such as Fig. 1. The input is the speech transformer and this

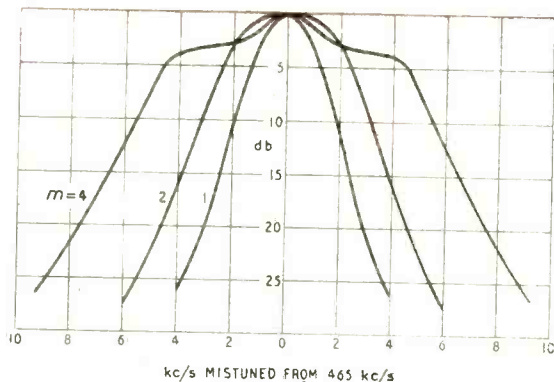

Fig. 9. Response of the circuit of Fig. 8 (b) at 465 kc/s.  $Q$  of coils=300. Turns ratio of tapping =  $Q/m$ .

contains leakage inductance which, it is found, can sufficiently represent  $L_1$ ; the output load is the speech coil and this also has inductance which can serve as  $L_3$ . Only the two condensers and the infinitely variable central inductance have actually to appear in the filter. The curves shown in Fig. 7 are the change in db resulting from cutting these elements in and out of the circuit. The steepness of slope averages about 34 db per octave, showing that all five elements are in fact playing their full part.

The principle of these filters can be usefully applied to the bandpass filter. Here the central element contains both an inductor and a condenser—it is, in fact, a tuned circuit. Fig. 8(a) shows the circuit now being considered. When redrawn as Fig. 8(b) it is instantly recognizable as two tuned circuits bottom-coupled by a third. The tapping is introduced so that the components of the central circuit can be of the same values as those of the outer circuits, and also to give a simple means of varying the impedance which provides the coupling. There are now two independent variables in the central element—its impedance as a coupling and its resonant frequency. Again, these variations of the central element exercise a pre-

## APPENDIX

Let  $E$  be the input voltage in series with  $a$

Let  $V$  be the output voltage across  $b$

Let  $W$  be  $\frac{\omega}{\omega_0}$

Then the response curve of all filters of this type can be expressed in the form:

$$\frac{V}{E} = \frac{b}{a+b} \cdot \frac{1}{A(B+CA)}$$

where  $A$ ,  $B$  and  $C$  are complex expressions independent of  $a$  and  $b$ . Their values are:

	3-element mid-series filter	5-element mid-series filter
A	$1 + jkW$	$1 - W^2 + j \frac{W}{k}$
B	$1$	$1 + jkW$
C	$j m W$	$j m W$

The mid-shunt formulae are the same with  $k$  and  $m$  inverted. A always contains a higher power of  $W$  than  $B$ . The  $C$  term, therefore, is always the term containing the highest power of  $W$  present in the expression, and this is proportional to  $m$ . Therefore variation of  $m$  governs the cut-off to a much greater extent than any other factor

† British Patent No. 601531 and patent pending

dominating control on the performance. Variation of its frequency shifts the centre frequency of the pass band, within limits, without unduly affecting its symmetry or width, while variation of the coupling impedance varies the width of the pass band without at all affecting its centre frequency. A variation of bandwidth of about 3 or 4 to 1 can be obtained without too bad a shape in the pass band.

This circuit has been used to provide variable

selectivity in i.f. couplers†. Typical curves are shown in Fig. 9. The coupler gives the full wall steepness of three tuned circuits, and the effective selectivity of all of them is controlled by only one variable. It follows also that in production these couplers can be satisfactorily ganged up to the desired i.f. frequency with one trimmer on the central circuit only, so long as the outer components are tolerably close to their designed values.

## SUNDERLAND RADAR

### *New Port Installation to be Worked by Pilots*

**T**HE application of radar aids to the movement of shipping in the harbours of the United Kingdom was carried a stage further in November last when the Minister of Transport opened a new experimental station at Sunderland.

The installation selected is a standard marine radar designed for use on board ship. The navigational requirements at Sunderland are well within its range, and a specially designed system, such as that installed at Liverpool for its 14 miles of narrow channel, is not necessary. Most of the docks are grouped just inside the harbour entrance and the navigational hazards to north and south of the entrance are adequately covered.

A marine-type radar has been in use for some time at Douglas, Isle of Man, but in this case, as at Liverpool, special observers are employed for its operation, and the traffic consists of passenger ships working to regular schedule. At Sunderland there is a big volume of general shipping, and the experiment is being tried of leaving the operation of the equipment in the hands of the pilots themselves, who can decide when and how it can be best used; for example, to help the pilot cutter to locate an in-

coming vessel, or to assist pilots already engaged in bringing in vessels under conditions of bad visibility.

Communication between pilots and the Pilot House ashore will be maintained by a two-frequency v.h.f. radio-telephone channel, the shore station working on 163.1 Mc/s and the pilots' transmitter-receivers on 158.6 Mc/s. The v.h.f. equipment has been supplied by the Automatic Telephone and Electric Company in association with British Telecommunications Research, and the portable units are similar in design to those employed at Liverpool. Additional coaxial resonant filters have been included in the receiver input feeders to reduce crosstalk between the transmitter of one equipment and the receiver of the other due to the close frequency spacing employed. The shore transmitter (Type PM1A) is rated for 10 watts output and employs amplitude modulation. A similar transmitter provides single-frequency simplex working on the marine International Guard Channel of 156.8 Mc/s, and Sunderland is the first port in the British Isles to be given this facility.

A continuous listening watch is kept by the pilot vessel and a 12-volt battery-operated transmitter-receiver (Type PM1C) is used, the batteries being charged from a generator on the main engine.

The radar installation consists of a Kelvin Hughes Type 1A (Series 2) instrument with 12-in diameter display. The i.f. signal and locking pulse are split after the pre-amplifier to provide a second display in another part of the building for experimental work by the Admiralty Signals Research Establishment—the technical authority for the installation. The scanner unit is mounted at the top of a 50-ft lattice tower, which also carries the coaxial dipole aeriels of the communications equipment.

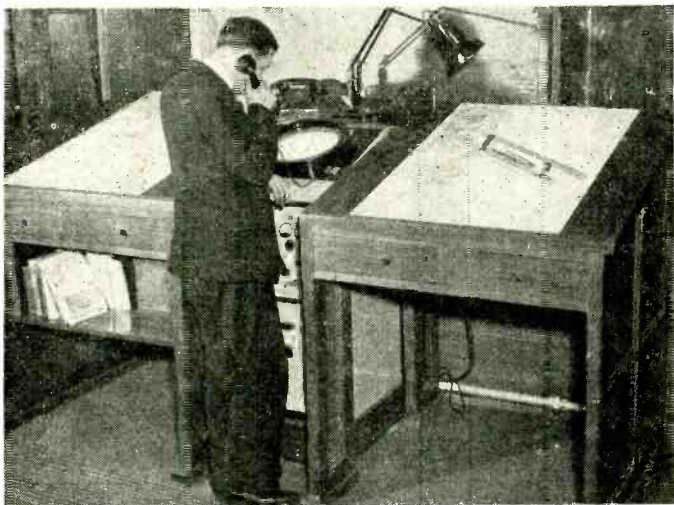

Radar display unit and chart tables in the Pilot House, Sunderland. Communication with pilots on duty is maintained by v.h.f. radio-telephony.



# Square-Wave Generator

By O. C. WELLS

*Practical Design Giving Three Repetition Frequencies at Low Impedance*

A SQUARE-WAVE generator is convenient for testing a.f. amplifiers, as well as being generally useful. By means of an oscilloscope and a sinusoidal input it is possible to see when a stage becomes overloaded and to measure the input amplitude for which it occurs, but in order to measure frequency distortion we need an a.f. source of continuously variable frequency. Using a square-wave input, there is no need to make an extended series of readings, as we can gain some idea of the distortion by examining the output waveform. This method was described on page 6 of *Wireless World* for January 1948, to show the effect of negative feedback on the Baxandall amplifier. There is no need to have a continuously variable repetition frequency, but it is a good idea to have several "spot" frequencies, and so be able to gain an idea of the low-frequency response by means of a low-frequency square-wave, and the top response by means of a higher repetition frequency.

The following, then, is a square-wave generator designed along these lines. Three spot frequencies are available, 80 c/s, 800 c/s, and 8 kc/s, each of which can be selected by a switch. The amplitude is continuously variable from zero up to about 50 volts peak-to-peak, whilst the output impedance is of the order of 150 ohms. The mark-to-space ratio is continuously variable from about 5:1 to 1:3. Two valves are used, both type EF50.

There is a choice of several methods of producing the square wave, of which the multivibrator might seem the most suitable. But to obtain a rapid rise on the square-waves it would be necessary to use at least one cathode follower, and even then we would have to add some sort of limiter. At least two double triodes would be needed. But the main disadvantage of this circuit is that it would necessitate switching two capacitors to change the frequency.

The transitron relay is capable of producing a

better square-wave, using a simpler circuit in which only one capacitor needs to be switched.

Referring to the circuit in Fig. 1,  $V_1$  is the transitron oscillator, producing a 100-V peak-to-peak waveform at its anode. As a point of interest, this valve, when connected up as shown, is unstable when the suppressor voltage lies between about -5 and -40 volts. If  $R_1$  is returned to a bias outside this range, however, the circuit will not self-oscillate, and will only produce a pulse when suitably triggered.

$R_2$  alters this suppressor bias, and so controls the mark-to-space ratio—and, to some extent, the frequency. (The repetition frequencies quoted above correspond to an exactly square output.)  $S_1$  selects the spot frequency without affecting the mark-to-space ratio, enabling  $R_2$  to be calibrated directly. If desired  $R_1$  can be made variable to give continuous frequency coverage, but if this is done the frequency and mark-to-space controls will interact. In practice the one control  $R_2$  is sufficient.

The negative half-cycles produced at the anode of  $V_1$  are by no means square, so it is necessary to add some sort of limiting circuit.  $V_2$  is a combined triode limiter and cathode follower, having the double purpose of limiting the negative peaks and providing a low output impedance by its cathode-follower action. An EF50 was used to give a low output impedance. Almost any valve will operate effectively in this position, so if for any reason it was desired to add some additional pulse-shaping circuit, one section of a 6SN7 double triode could be used for  $V_2$ , leaving the other section for the new device.

Fig. 2 shows the output waveforms at 80 c/s and 8 kc/s. The 8 kc/s waveform is not so square as the other two, but is nevertheless still useful.

To give a 50-V peak-to-peak output, 400-V h.t. and bias supplies are needed. The circuit will, however, operate from half these voltages at somewhat reduced amplitude.

Left: Fig. 1. Circuit of the square-wave generator.

Fig. 2. At (a) is the waveform produced at a repetition frequency of 80 c/s, and at (b) is the waveform at 80 kc/s.

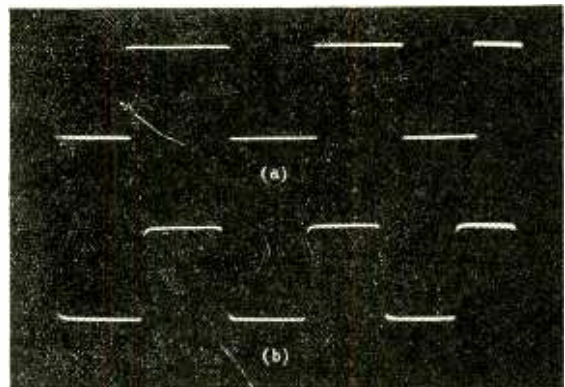
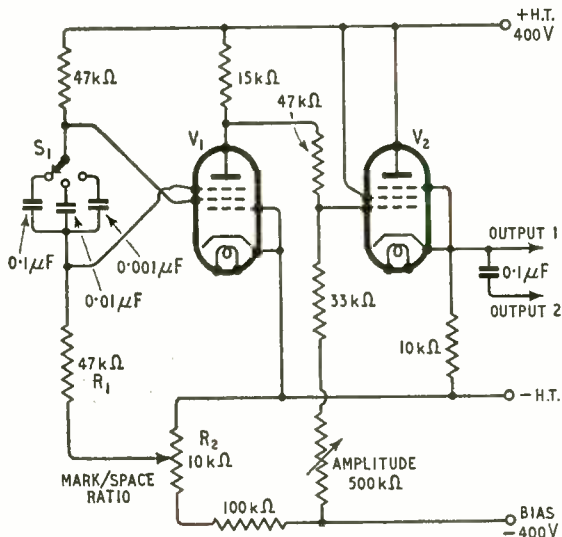

# Manufacturers' Products

## New Equipment and Accessories for Radio and Electronics

### Wave Analyser

AS an aid to rapid medical diagnosis from electro-encephalographic recordings, the Edison Swan Electric Co., of 155 Charing Cross Road, London, W.C.2, have produced an instrument for automatically analysing a complex waveform in a very short space of time. When dealing with a continuous e.e.g. waveform it provides a complete analysis every 10 seconds and presents this in written form on the part of the record to which it refers. The problem of analysing aperiodic functions is solved by integrating the outputs of pre-tuned frequency selectors over a period of time.

### Broadcast Receivers

A FEATURE of the new "Twinvicta" a.c./d.c. mains/battery portable, made by Invicta Radio Ltd., of Parkhurst Road, London, N.7, is the extremely attractive and colourful material covering the cabinet, a new woven plastic called "Tygan," which is claimed to be extremely durable and easily cleaned. The receiver weighs 9lb and costs £14 12s 6d. Two new sets with the emphasis on quality of re-

production are the "Mayfair" radiogram, made by Ace Radio Ltd., of Tower Road, London, N.W.10, and the model "750" receiver by Rainbow Radio Mfg. Co. Ltd., of Mincing Lane and Mill Lane, Blackburn, Lancs. Both use 10-in speakers, and some attention has been given to the acoustic designing of the cabinets.

### Aerial Multicoupler

THE purpose of this equipment, introduced by The Plessey Company of Ilford, Essex, is to permit the operation of up to ten communication receivers from a common aerial without cross-modulation effects or loss of individual signal strengths. It consists of a wide-band amplifier with filters, giving a pass range of 2-20Mc/s flat to within  $\pm 3$ db, and this arrangement feeds into ten cathode-follower stages which are designed to work into 75- $\Omega$  unbalanced loads. The amplifier will handle signals up to 250mV without overloading or excessive cross-talk, and down to 1 $\mu$ V without the noise becoming appreciable. It is designed to an International Aeradio Specification and is

suitable for international rack-and-panel mounting.

### Loudspeakers

AS a result of the considerable interest shown in their "Stentorian" 12-in Concentric Duplex loudspeaker, Whiteley Electrical Radio Co. Ltd., of Victoria Street, Mansfield, Notts, are now producing this model in an acoustically designed vented cabinet at £32 10s. It stands 3ft high and 2ft wide, and is finished in polished walnut. From E. K. Cole Ltd., of Southend-on-Sea, Essex, comes the Model ES115 extension speaker, an 8-in p.m. dustproof type in a plastic cabinet, at £2 17s 6d. It will handle a 3-watt output and has an on/off and volume control flush-fitted in the side.

### Picture-telegraph Equipment

ONE feature of the picture-telegraph equipment now being made by the General Electric Company is that the transmitter can be converted for use as a receiver when required by a simple interchange of

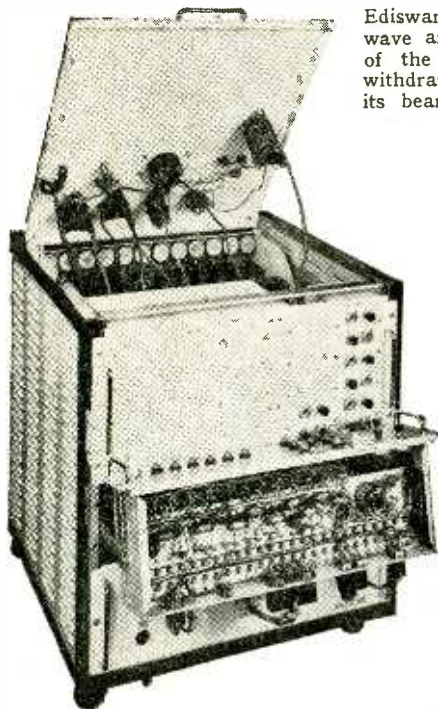

Ediswan Mark II low-frequency wave analyser with top open. One of the chassis sections has been withdrawn and swung round on its bearings for maintenance.

Right: Ekco extension speaker, model ES115. The plastic case can be supplied in either beige or maroon.



"Twinvicta" mains/battery portables, showing two of the patterns available in the new "Tygan" covering material.

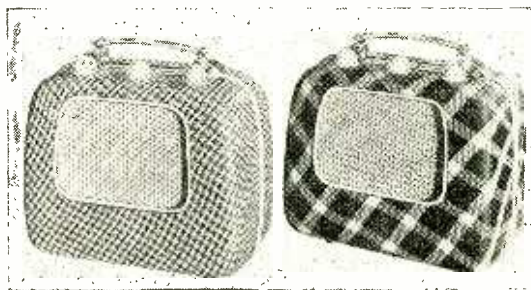



parts. At normal transmission speed a 10in x 8in picture can be sent over telephone line, carrier circuit or radio link in 14 minutes, although this time can be reduced to seven minutes at the expense of picture quality.

Definition is the highest possible within the limits prescribed by the C.C.I.T., and the equipment will work in conjunction with any other picture-telegraph equipment which complies with these standards. Pictures can be received as positives on photographic paper for direct viewing or blockmaking, or as negatives when a quantity of prints are wanted.

### Miniature Hearing-Aid

**G**REATLY improved intelligibility is claimed for the new "Micro-pak II" one-piece hearing-aid, which has a high maximum gain (55db air-to-air) and is provided with optional a.v.c., in addition to manual volume control, to ensure a maintained comfort level and freedom from loud noise. A recessed crystal microphone is used, followed by three stages of amplification, with the output pentode feeding into either air- or bone-conduction receivers. The overall response is sensibly flat, but a bass cut for tone control is introduced when on a.v.c.

Produced by Bonochord, Ltd., 48 Welbeck Street, London, W.1, this model measures 3½in x 2¾in x 1½in, and weighs only 5oz complete with batteries. It gives 350 hours of life on a 15-V h.t. battery, 10 hours of l.t. life on a standard "pen" cell,

and costs less than ½d per hour to run. The price is 30 guineas.

### Germanium Rectifier

**T**O meet the needs of designers who want a low reverse current at a reasonable price, the General Electric Co. Ltd. have introduced the GEX45. This has a reverse current of 10-30µA and costs 16s, as distinct from the 10µA of the GEX55, which costs 30s. The forward current is approximately 8mA at +1 volt and the turnover voltage is greater than 60V.

### Miniature Transformer

**A**N exceptionally small transformer, giving an impedance ratio of 250:1, has been designed by John Bell and Croyden, of 117 High Street, Oxford. It is suitable as an output transformer for hearing-aids and the primary winding can be included in the anode circuit of the output valve, giving an inductance of 28H at 200µA d.c. or 12H at 1mA d.c. There are 5,000 turns of 48 s.w.g. on the primary and 100 turns of 38 s.w.g. on the secondary. Using "F" size laminations and a moulded bobbin, the outside dimensions work out to 0.752in x 0.438in x 0.55in.

### Educational Oscilloscope Units

**T**O meet the needs of schools and colleges for a moderately priced demonstration instrument, the Equipment Division of Mullard

Electronic Products Ltd., Century House, Shaftesbury Avenue, London, W.C.2, has introduced a c.r.t. unit B100 and an associated time-base/amplifier unit B101 that together provide most of the features of the modern oscilloscope. Each unit has its own internal power supply. There is a 3-in c.r.t. in the B100, with vertical and horizontal deflection sensitivities of about 0.2 mm/V. If desired, the vertical and horizontal amplifiers in the B101, which have a frequency response of 25 c/s to 30 kc/s, can be used without modification as independent general-purpose amplifiers. The B100 unit costs £12 12s and the B101 unit £15.

### Transmitter Feeder Cable

**D**ESIGNED for handling large amounts of r.f. power, the new Telcon AS.84.A1 semi-air-spaced cable has shown itself capable of carrying 20kW at 45 Mc/s without difficulty. Regarding its propagation characteristics on wide-band transmission, tests on a 280-yard length have shown that the voltage standing-wave ratio would not be worse than 0.98 over a 10 Mc/s band centred at 60 Mc/s. The inner conductor is a solid copper wire of diameter slightly above ¼in, and is supported at intervals by a series of interlocking Telcothene mouldings. The outer conductor is a seamless extruded tube of aluminium. The Telegraph Construction & Maintenance Co. are at 22, Old Broad St., London, E.C.2.

Right: Mullard educational aid; on the left is the time-base/amplifier unit B101 and on the right is the cathode-ray tube unit B100.



Bonochord "Micro-pak II" hearing-aid, showing the drum-type volume control, microphone grille and pocket clips.

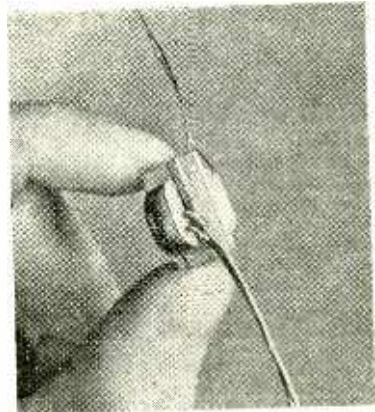

Belclere miniature transformer for use in hearing-aids, showing its size in relation to the human hand.

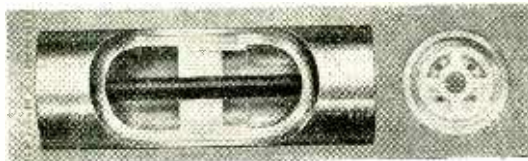

Telcon transmitter feeder cable. On the left is a cut-away view to show the interlocking mouldings which support the inner conductor.

# UNBIASED

By FREE GRID



Maybe in May

## Source of the Saucers

FLYING saucers have taken the place of the Loch Ness Monster, but whereas the monster did no greater harm than to frighten a few Scotsmen out of their wits, thus leading them to forswear further indulgence in the national beverage, this new menace is far more serious. By acting as transient reflectors and so causing intermittent distortion and fleeting ghost images on our television screens, these so-called saucers are proving a very real source of trouble.

At present the trouble is not excessive because these saucers are few in number, but like Hitler, who also began in a small way, they will become uncontrollable unless dealt with promptly. Obviously the first thing to do is to find out whence they come and deal with them at the source; for when plagued by wasps it saves a lot of time if we can locate their nest.

Now it has been suggested that they come from another planet but astronomers insist that their observations show that, with the exception of the Earth, the Sun's satellites are incapable of supporting life, and who am I to disagree with such learned men? But we must not forget, as Mr. Hoyle, the erudite astrophysicist from the banks of the Cam, has reminded us over the air, that we cannot absolutely rule out the possibility that some of the myriad sparkling spheres, with which the heavens are bespangled, may possess some inhabited satellites. This, however, does not take us very much farther for, as Mr.

Hoyle also tells us, the nearest stars to us, which for the sake of argument we will assume to possess inhabited planets, are roughly three light-years, or in more homely figures 17,330,476,800,000 miles, distant from us. Now since the observed maximum speed of the saucers is said to be a mere eighteen thousand miles *per hour* it would, leap years included, take them rather more than twenty-two thousand years to do the round trip ("if in doubt, work it out" as the pedagogic maxim puts it, but in the interests of domestic harmony *don't* "Ask your Dad" in this case).

It is clear, therefore, that we must look for a "home-counties" planet in our own Solar System which has so far eluded the eye of the astronomer and I think I have found it by means of radar. Basing my work, like many others, on the speculations of Aristarchus and other ancient Greek philosophers, I have discovered that this new planet travels round the same orbit as that of the Earth but, as it is 180 degrees out of phase and moves at the same speed, it is always on the opposite side of the Sun to us; therefore, we can neither see it nor get a direct radar echo from it. But any of you who are proficient at billiards will readily understand how an indirect radar-echo can be obtained by a simple there-and-back cannon off one of the other planets when it is in a suitable position. I am hoping, therefore, to get the Government to allow me to demonstrate this to the public at the Shot Tower radar installation which is being erected for this year's Festival of Britain. The echo from it will automatically ring the bell and return the money of successful shooters. I propose to give the planet the appropriately commemorative name of Radaria.

## Radio Jubilee

THIS year we enter upon the second half of the 20th century and it would surely be fitting that a section of this year's radio show should be devoted to a review of the tremendous progress made in the past fifty years. The year marks for one thing the jubilee of transatlantic wireless, as it was on December 12th, 1901, that Marconi first linked us with the New World, and it was in 1901, too, that the first British merchant ship, the *Lake Champlain*, was fitted with wireless.

It is, however, rather a difficult thing to stage a suitable review of the past half-century of radio and make it interesting to the general public. It can so easily degenerate into a moth-eaten dry-as-dust ex-

hibition of ancient sets and components. We want to see and hear the things in action and also hear the B.B.C. artists as we heard them nigh on 30 years ago when loudspeakers, driven by output valves as unbiased as myself, belloyed like the bulls of Bashan, and famous public entertainers refused to have anything to do with broadcasting. In other words, we want something that is alive and interesting like the annual run to Brighton of ancient cars when pioneer motorists celebrate their red-flag emancipation day which, like Marconi's first British patent, was an outstanding event of 1896. It is astonishing how few listeners realize how old wireless really is; not many, for instance, know that the valve was invented in 1904.

Perhaps the organizers of this year's National Radio Show will give my suggestions for enlightening the man in the street some thought.

## Power-cut Pageantry

I WONDER why no radio manufacturer has yet marketed a set which automatically switches itself over to batteries during a power cut. Such an instrument is a logical development of the battery/mains portable now available. Say what you will, power-cuts have come to stay. At present unavoidable, they will eventually remain as part of the rich pageantry of our national life like the posy which Judges of the High Court still carry on certain occasions even though the combined efforts of the medical and plumbing professions have long since removed the necessity for it. I am surprised, too, that no effort has yet been made to enable an a.c. mains clock to keep itself going during a power-cut; surely the answer is a battery, a vibrator, a transformer and an automatic switching arrangement.



OUR National Life.



# LETTERS TO THE EDITOR

*The Editor does not necessarily endorse the opinions expressed by his correspondents*

## A.M. versus F.M.

HAVING been interested in this controversy for a long while, I constructed an a.m./f.m. receiver some time ago, but have only recently had an opportunity to carry out some tests on the Wrotham transmissions, particularly on the fidelity and interference angles. The results have not altogether surprised me, as I knew from experience on television sound that e.h.f. a.m. was capable of very high quality, but prone to ignition interference; however, I was agreeably surprised by the almost complete absence of this virulent interference (and, incidentally, any other kind) on the Wrotham transmissions.

Comparing the a.m. with the f.m., I find little to choose between them as regards fidelity and lack of interference; the a.m. appears to be the stronger signal, though ample pick-up can be obtained on an ordinary indoor aerial from both signals. The fidelity of both seems to be effected by land-line considerations, and much of the programme material shows up badly when used to modulate these high-fidelity transmissions, though occasional "live" studio broadcasts are first-class.

I consider there is a definite future for e.h.f. broadcasting as an unlimited number of low-power transmitters would entirely solve the problem of 100 per cent coverage (which is far from being achieved with the present system) without the disadvantages of sharing frequencies, and would at the same time provide much better quality.

However, to return to the a.m./f.m. controversy, considering the additional complications and extra cost of the f.m. receiver, which, in my experience, is in no way superior to its a.m. counterpart, I can see no earthly reason for the controversy. Let's have lots of a.m. broadcasting on e.h.f., and those of us with high-fidelity equipment will at last get value for their licence fee!

R. C. BURNELL.

Wallington, Surrey.

## Television Load

THE recent extension of the television Children's Hour from Sundays to week-days seems likely, with the present timing, to have unfortunate results in several directions. The highest peak electricity load during the six winter months

occurs around 5 p.m. At that time it is the rule rather than the exception in my own district (which is no doubt typical) for the mains voltage to be reduced 15 per cent in order to shed load. This is just the time at which the children's television is put on. To the British Electricity Authority it means that a new load, of the order of 100,000 kW, and growing rapidly, is being placed on top of their highest peak. To the radio industry it means that 6.3-V heaters of valves and cathode-ray tubes are being run at 5.35 V, a drop of rather more than double the safe maximum prescribed in the Code of Practice issued by the B.R.V.M.A., which states that low heater voltages are as much to be avoided as high voltages. To the radio dealer it means that television sets (especially the modern a.c./d.c. type) are likely to go out of adjustment and give poor results generally, so that his customers complain.

The remedy would seem to be to delay the children's television programme on Monday to Friday until, say, six p.m.

M. G. SCROGGIE.

Bromley, Kent.

## "Phase Shift Oscillators"

THIS article by W. G. Raistrick in your November issue is of considerable interest in view of the unusual merits of the circuit concerned.

We feel, however, that other work on this circuit is worthy of mention. The principle of the valve phase shifter was described by Dome<sup>1</sup>, and an oscillator incorporating this by Villard under the title "Tunable A.F. Amplifier."<sup>2</sup>

Villard's article is particularly valuable in that it mentions the use of the circuit as a selective amplifier by the use of 180 degrees phase change. Villard claims this gives a sharper null than either twin tee or Wien Bridge networks. He also points out a unique feature of the oscillator, namely its ability to produce two outputs 90 degrees apart in phase.

One further point. For successful operation of this circuit it is desirable that cathode and anode load resistors should be fairly closely matched, and also that the im-

<sup>1</sup> *Electronics*, Dec., 1946.

<sup>2</sup> *Electronics*, July, 1949.

# TRIX

*Quality*

## SOUND EQUIPMENT



MODEL T.101

12 Watt

## High Fidelity AMPLIFIER

This latest Trix model is a versatile high fidelity amplifier suitable for numerous applications. It incorporates special twin channel tone compensation circuits with controls for bass and treble boost, and push-pull output stage with inverse feedback, thus providing exceptional quality of reproduction.

Separate input sockets are fitted for gramophone pick-up, microphone and radio inputs with appropriate selector switch on the front panel.

A socket is also incorporated for H.T. and L.T. supply to feed an external mixer or radio feeder unit.

## LONG-PLAYING RECORDS

The T.101 gives superb results with "long playing" records as well as standard types.

The output is high impedance, allowing several external speakers to be connected, on long lines without loss of power.

Full details of this amplifier and other models in the large Trix range of Sound Equipment available on request. Send for latest catalogues and price lists.

THE TRIX ELECTRICAL CO. LTD.  
1-5 Maple Place, Tottenham Court Road,  
London, W.1. Phone: MUSEum 5817  
Grams & Cables: "Trixdio, Wesdo, London."

AMPLIFIERS · MICROPHONES · LOUSPEAKERS

pedance of the power supply should be low in comparison. As the loads may only be of the order of a few hundred ohms this may cause trouble at low frequencies.

W. BACON,  
D. P. SALMON.

Hindhead, Surrey.

**“Curious Effect”**

ADDITIONAL experiences with flashes and streaks of light on the screens of cathode-ray tubes after switching off may be of interest

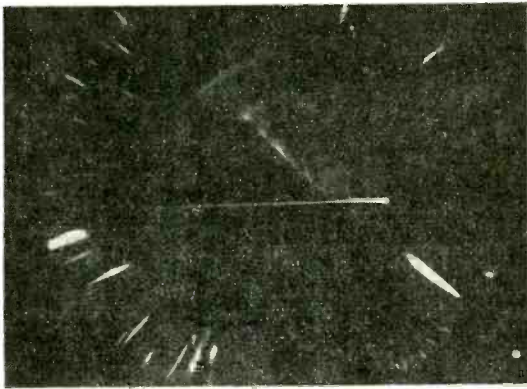

to your readers. The tube in question was used in a high-speed oscillograph for transient observation and photography. It was a Du Mont 5RP11A, using a gun voltage of 4 kV and a post-deflection accelerator voltage of 20 kV.

It has frequently been observed that, after switching off, luminous phenomena of various types occurred. These phenomena consisted of any or all of the following.

(a) Occasional general illumination over an area of a few sq. inches, which was of low intensity.

(b) Bright spots of varying intensity, some bright and some dim. These were oblong in shape and radial in direction, and have been observed as intermittent flashes, or as moving flashes of a few seconds duration, or more.

(c) Occasional small patches of light, which could be moved slightly by rubbing the tube face with the hand or a cloth.

Of these three types (b) was the most frequent, and could often be increased in intensity by rubbing the tube face with a cloth or by hand.

These phenomena did not always appear on switching off, the most favourable time for their appearance being when the apparatus was thoroughly warm. However, rubbing the tube face would often produce them if they had not appeared, or increase and intensify them if they were weak. It would also prolong

the duration of their appearance.

A voltmeter permanently connected across the e.h.t. supply definitely indicated that such supplies were off. The phenomena appeared sometimes instantly, when it was reasonable to suppose that the cathode was still hot, but at other times they appeared some time after, or persisted for such a time that it seemed unlikely that the cathode would even be warm. The tube did not use any Perspex screen, as has a previous example given in these columns. The electrostatic charges, presumably responsible for

these phenomena, seemed either to be on the outer surface of the tube or possibly internally on various parts of the tube itself. The fact that the phenomena appeared most frequently and strongly in summer with a warm, dry day, and when the apparatus had been working for a long time and was thoroughly warm, would seem to indicate that the origin of these flashes was outside the tube rather than inside.

The accompanying photograph, made accidentally owing to a mains failure at the time of exposure, shows some of the phenomena, which must have occurred shortly after the supplies were cut off, as the camera shutter was only open for a few seconds. (Note, the zero line had been previously recorded.) It illustrates equally well the phenomena which occurred much later after switching off, and lasted for a few minutes.

R. RITTER.  
RICHARD G. PARR.  
Zürich, Switzerland.

**Pickup Input Circuit**

AN additional input circuit for the Acos GP20 pickup may be of interest to readers in view of your article “Pickup Input Circuits” in the November 1950 issue. It is based on the article “Negative Feedback”

in the March 1950 *Wireless World*.

I have used this circuit in an attempt to approximate to curve 1 rather than curve 2. The effective input impedance is increased by negative feedback to about 6 MΩ, and a very satisfactory bass response is obtained from 78 r.p.m. records.

Nottingham.

**Beauty and the Beholder**

I WAS interested to read in your October issue the letter on aerials as things of beauty—or otherwise.

As to outdoor television aerials, I doubt if the “Dictators of Town and Country Planning” can control the erection of an outdoor aerial; certainly not an “H” on a short mast, anyway. Multiple elements on 50-foot masts might be a different proposition.

My reasons for this contention may be found in Section 12 of the Town and Country Planning Act, 1947, which exempts from the provisions of the Act (and therefore the dictates of local planning authorities) certain things. One of these is: works for the improvement or alteration of a building which do not materially affect the

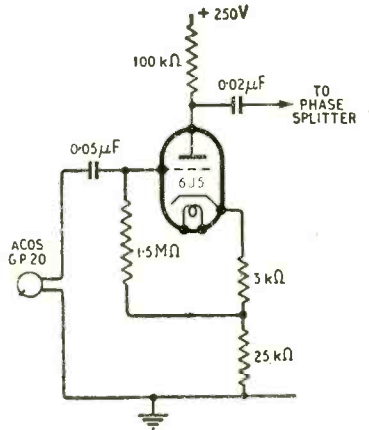

Negative feedback applied to increase input impedance and (below) response of GP20 pickup taken with Decca K1804 test record. 1, on open circuit; 2, with 0.5 MΩ load.

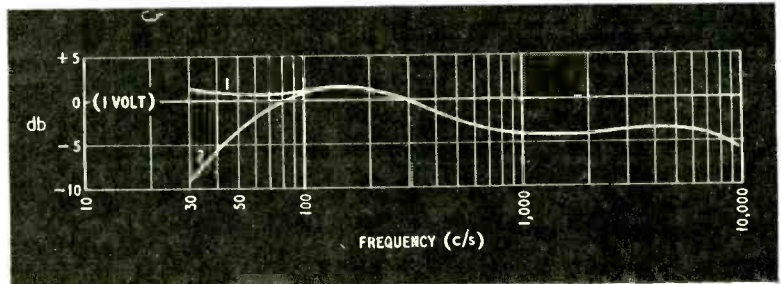



external appearance thereof. I think the ordinary "H" on a chimney stack (with a short mast, if you like) comes within this provision.

Now, of course, the local planning authority may think otherwise. Very well, let them; the Act also contains, in Section 17a, provision which says: Anyone proposing to do something to a building, and being uncertain whether or not (1) his proposals come within the scope of the Act, and (2) if they do, whether or not they require permission, can apply to the local planning authority to determine these points. This being so, let anyone wishing to erect an "H" and fearing the wrath of the local planning authority apply for a determination, as mentioned above. If the answers to (1) and (2) above are "No," then he may proceed. If the answer to (1) is "Yes" and to (2) "No," then again, unless the local planning authority go to some trouble by using other provisions of the Act (which is, I think, fairly unlikely) he may carry on with his proposal. If the answer to (1) and (2) is "Yes," then the local planning authority can refuse permission.

But in this last case the applicant can appeal to the Ministry of Town and Country Planning on two points: first, that his proposal is not within the scope of the Act, and, secondly, even if it is within the scope of the Act, that permission should be granted. I doubt very much if, on such an appeal, the Minister of Town and Country Planning would refuse permission. I think he would overrule the local planning authority in most cases.

So let some would-be viewer take action on the lines mentioned above; perhaps someone has already done so, in which case, I suggest the result should be of interest to many readers.

W. WILSON.

Shelton Dale, Nottingham.

### "Tolerances and Errors"

WHEN (in the November issue) I likened the manufacture of resistors to shooting at a target "from a considerable distance" it was with a certain naughty provocativeness. So it didn't altogether surprise me when a well-known resistor manufacturer reacted. From what he says it appears that the hit-and-miss method I described is no longer practised in the enlightened modern resistor factory.

It seems, then, a good opportunity for a resistor manufacturer to tell us how he does it now. It may be that when making  $\pm 5$  per cent resistors he stands nearer to the target.

I still suspect that before I bought my  $\pm 20$  per cent stock someone had picked out the best ones—but perhaps they were made in the bad old days. "CATHODE RAY."

# SWITCHES

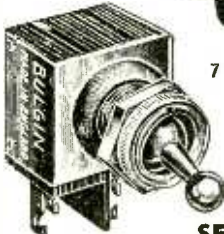
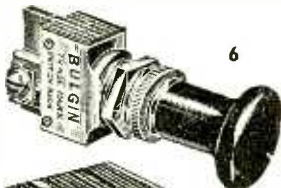
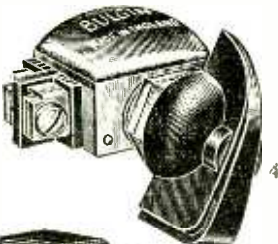
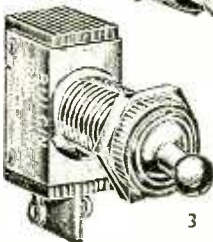
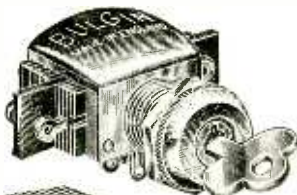

'Bulgin' Miniature Switches are truly Great. Made up of as many as 50 different parts, each part precision made and type checked and gauged, these switches are strong, compact, robust and reliable, guaranteed for 25,000 operations.

The choice of operating-style is vast. ROTARY, TOGGLE, PUSH-PULL, KEY, PRESS-KEY, MICRO-SENSITIVE, AUTOMOBILE, APPLIANCE, THERMAL-DELAY and FLASHER, PEAR-DOLLY, BALL-DOLLY, FORKED-DOLLY, EXTRA-LONG BUSH, LONG-BUSH, SHORT-BUSH, DOUBLE-POLE, SINGLE-POLE, BIASED, ON-OFF . . . We should need the whole "Wireless World" to tell you all about our switches; full details are given in our Catalogue No. 185 (185/WW) Price 1/- post free. Here are a few brief examples:

1. List No. S.365, 366. Single-pole On-off Switch. Press for ON (S.365) Press for OFF (S.366). These switches are ideal for Refrigerators, cupboards, etc. Roller-Contact Q.M.B. action, highest grade laminated bakelite insulation, fitted with silver-plated solder-tags for contacts. Fixing is  $15/32$ in.  $\phi$  on up to  $3/8$ in. thickness. Thread 32 t.p.i., Whit-form. Plunger travel is approx.  $1/8$ in.

2. List No. S.324. Double-pole, change-over, semi-rotary Key-switch. Working voltages, 6-250 a.c. or d.c. Max. test voltage 1,000 peak: insul. res.,  $\leq 40M\Omega$ . Contact res.,  $\geq 0.01\Omega$  (10m $\Omega$ ) at: 6V. and 2 x rated amps. Angle of operation,  $60^\circ \pm 10^\circ$ . Reverse force against internal stops,  $\geq 7$ lb.-in. Clean Make-break snap action. Fixing is by  $15/32$ in.  $\phi$  hole, preferably with re-entrant 'key'  $3/8$ in.  $\times$   $1/8$ in.

3. List No. S.400. Single pole Make-break, long-bush type, for panels, not greater than  $3/8$ in. thick. Tested at 1 KV. peak (= max. test V.) Dry I.R.  $\leq 40M\Omega$  at 500V. This switch, with S.401 and S.404, is suitable for automobiles or mains uses.

4. List No. S.565. (Shown fitted with K.107 Knob) Semi-rotary Q.M.B. snap-switch. Shafts are  $1/16$ in.  $\phi$  (0.247in.—0.249in. actual) and take standard knobs. Shaft is not flattened, this is a great advantage when legended knobs are used; the switch may then be mounted in panel any way up if space is tight and the legend is still in horizontal position. Fitted with solder-tags or terminals for connection.

5. List No. S.332. Single-pole, Make-break, On-off Switch with forked-dolly for mechanical operation by  $3/16$ in.  $\phi$  pins or equivalent, moving on  $3/16$ in. radius. Average operating angle,  $45^\circ$ . Peak Amps. at 6V.  $\sim = 6$ , at 110V.  $\sim = 4$ , at 250V.  $\sim = 3$ .

6. List No. S.220 and S.390. Q.M.B. Toggle-action push-pull models. Popular contacting-combination-push-pull types, fully insulated from case, and suitable for 6-250V. (i.e., Automobile as well as mains uses). Both these switches are Single-pole Make-break, and are fitted with rear terminals for contacting. Pull for 'ON' (S.220) and Pull for 'OFF' (S.390.) Fitted with polished black bakelite knob, unscrewable for mounting switch to panel.

7. List No. S.277. Double-pole Q.M.B. Toggle switch for 6-250V. circuits. In accordance with wise, modern, safety requirements, double-pole switches are in greater demand than ever before. Suitable for 6—250V. circuits a.c. or d.c. Tested at 1,000V. peak (= 4 times working voltage): insulation resistance  $\leq 40M\Omega$ . Contact resistance =  $\geq 0.01\Omega$  (10m $\Omega$ ) at 2 x rated amps. Rated amps may be doubled at 6—12 Volts.

SEND FOR CATALOGUE (185/W.W.) NOW  
PRICE 1/- POST FREE



**A.F. BULGIN & CO. LTD**  
**BYE-PASS ROAD BARKING**  
TELEPHONE: Ripplaway 3474 (5 lines)

# RANDOM RADIATIONS

By "DIALLIST"

## *Would You Like One?*

ONE QUITE OFTEN hears or reads that one of the things mankind most needs to-day is a television equivalent of the crystal set. People who air this opinion not infrequently show a few moments later that they have never stopped to think what they mean by it; for almost in the next sentence they add that much larger images than those now usual must be provided. The great advantages of the crystal set are that it can be bought cheaply, that it is very simple, that almost anyone who wants to do so can make it and that it can be run at next to no cost. Fine! But what does it do? The best that it can furnish is headphone reception of the broadcast programmes at comparatively short ranges. The equivalent television set, were there such a thing, would presumably present its images on a one-inch screen, with headphone reception of the accompanying sound. I cannot see any rush for such an instrument. Can you?

## *If Wishes Were Horses . . .*

If and when you can get them down to brass tacks, you find that what those who say such things really have in mind is that the world is longing for the advent of the high-grade receiver, giving at least a 16 x 12-inch image, at a price well below £25. If that be so, the world, one fears, will go on longing, at any rate for quite a bit yet. Unless—as is quite possible—some entirely new and far simpler method of transmission and reception is evolved, television must continue to be something of a luxury. To my poor brain it seems that home television is an amenity, on a par with a good piano or a home-movie outfit, to be earned, should you desire to have it, by effort and by saving. And what you want to get for your money is a set which can be relied upon to give good results.

## *There's a Limit to Cheapness*

What I'm driving at is that, when you come to buy a television set, you cannot expect to get more than you pay for. The bare facts are that as things are at present it must

contain upwards of 15 valves; include a considerable number of circuits capable of being finely adjusted and of staying put, once they are adjusted; and, if you want a big picture, have either a monster c.r.t. for direct presentation, or—if you prefer projection—a small super-brilliant c.r.t. *plus* devices for raising the e.h.t. to 16,000-20,000V, *plus* an optical system, *plus* a separate screen. The set should also be easy to operate and perfectly safe. To provide all these things the maker cannot go below a certain minimum price unless he is prepared to cut his costs in undesirable ways. There may be a real danger in that the cry for cheaper and cheaper television sets may lead to a price war and to the large-scale production of over-cheap sets which not only give a comparatively poor performance when at their best, but develop into constant and expensive sources of trouble.

## *Valve Symbols*

IT WAS MENTIONED in the November Editorial that the revised edition of the British Standards Institution's "Letter Symbols for Electronic Valves" (B.S. 1409:1950) bears on its cover a most unfortunate statement that the symbols which it lays down are intended for use mainly in manufacturers' catalogues and such like. Myself, I read this statement with a horrid sinking feeling; but I felt a bit better when I had time to think over its implications. If valve manufacturers and other members of the radio industry are going all out for the use of the symbols in their catalogues and other "literature" (and presumably they are, for they played a major part in evolving them), their customers will have perforce to be familiar with them, or they will not be able to follow what they read. The symbols, then, are bound to become established as a kind of *lingua franca* of radio technique in this country. Those who write or publish books and articles would be foolish indeed if they did not use them, knowing, as they must, that these symbols are parts of a language with which all their readers must have at any rate a nodding acquaintance. It would have been

far better, admittedly, had the statement in question not appeared on the cover of B.S. 1409:1950. Better still would have been one recommending the adoption of the symbols by all British writers, teachers, publishers and manufacturers concerned with the advancement of electronics.

## *International Standards Lacking*

Probably the most one can pray for is that the technical terms and symbols used in one's own country may achieve standardization, for we seem to be drifting farther and farther away from the international systems that were once inaugurated with such high hopes. A mathematical friend to whom I said something of the kind promptly pulled me up short. "In my particular branch," said he, "we have been a bit more sensible. All the signs and symbols of mathematics, which is a really international language, are completely standardized throughout the world." I pulled an old envelope from my pocket and wrote on it:—

I.432

"What," I asked, "would that convey to a Frenchman or a German?" "Why, one thousand four hundred and thirty-two, of course." I explained that it would mean one point four three two and that either of them would write the number he had mentioned as:—

I.432

Electronics, being one of the newest branches of science, probably suffers more than most from lack of international standardization, for each country tends to adopt its own set of terms and signs for advances and discoveries which it makes simultaneously with other countries.

## *Sunspots Again*

ONE DOES NOT ENVY engineers engaged in keeping telecommunications going during disturbances due to sunspot activity, such as we had at the end of November and the beginning of December. World traffic was very heavy at that time and there were longish periods of almost complete blackout, particularly in northerly and southerly directions. All sorts of ingenious expedients have to be adopted. I was told that on this occasion messages to Australia, which normally go direct by radio, were at times sent by cable to America, by radio across that continent and by cable to their destination.